

COVER FLANGE (F)

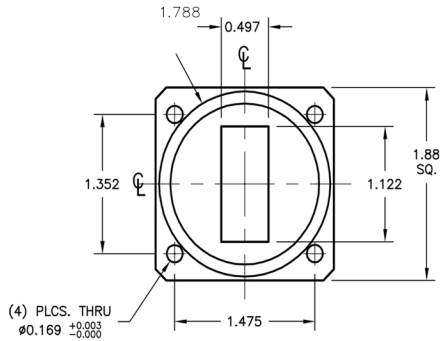

GROOVED FLANGE (O)

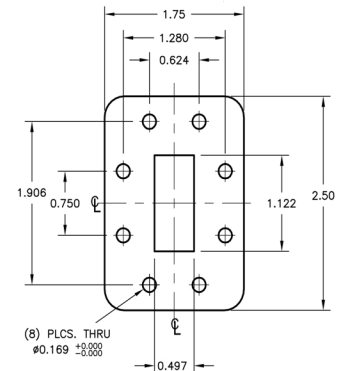

CPRF FLANGE (R)

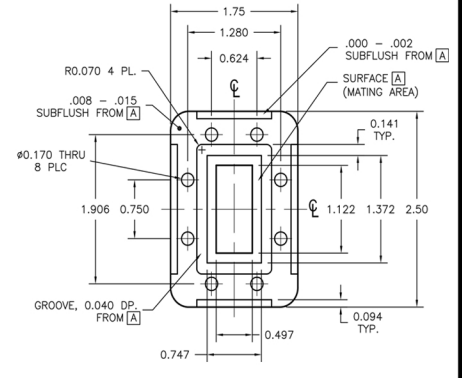

CPRG FLANGE (G)

MECHANICAL SPECS:
BENDING RATING (Rad (in)):
STATIC-E-PLANE: 2 H-PLANE: 3
REPEATED-E-PLANE: 8 H-PLANE: 12
TWISTING RATING (±deg/ft):
STATIC: TOLERANCE-79
TWIST: 20
MAX OPERATING PRESSURE: 45 PSIG
*AVAILABLE LENGTHS: 12", 18", 24", 36", 48", 60", 72"
AVAILABLE JACKETS: NEOPRENE (N)
FLANGE THICKNESS: 0.250"

ELECTRIC SPECS:
OPERATING FREQUENCY: 7.05 - 10.0 GHZ
MAXIMUM IL ATTENUATION db/ft: 0.9
MAXIMUM VSWR: <36" COVER FLANGE - 1.07
PLAIN/CHOKE FLANGES: 1.1
POWER RATING CW (kW): 1.5

ORDERING INFORMATION				
MODEL #	W/G SIZE	LENGTH (in or MMS)	FLANGE 1	FLANGE 2
AST1640	6	OPTIONAL	OPTIONAL	OPTIONAL

SAMPLE: AST1640-6-18-0-F
18" WR112 FLEX W/ ORING & FLAT FLANGES

REVISIONS		APPROVALS			
SYM	DESCRIPTION	DATE	ENGR	PROD	Q.A.

PROPRIETARY INFORMATION
THIS DOCUMENT CONTAINS PROPRIETARY INFORMATION WHICH SHALL NOT BE REPRODUCED, TRANSFERRED TO OTHER DOCUMENTS, DISCLOSED TO OTHERS, USED FOR MANUFACTURING OR ANY OTHER PURPOSE WITHOUT PRIOR WRITTEN PERMISSION FROM AST.

BREAK ALL CORNERS AND SHARP EDGES

UNLESS OTHERWISE SPECIFIED	DRAWN		
FRACTIONAL ± 1/32	CHECKER		
DECIMAL .XXX ± .010	MECH. ENGR.		
ANGULAR .XX ± .020	ELEC. ENGR.		
± 1/2"	PROJ. ENGR.		
MATERIAL: NOTED SPEC:	CHIEF ENGR.		
FINISH: NOTED SPEC:			

WR112
FLEXIBLE WAVEGUIDE
DRAWING # AST1640-6
SCALE NTS

AST MICROWAVE
754 Fortune Crescent
Kingston, ON
K7P 2T3, Canada
613-384-3939

SHEET 1 OF 1