

Transmit path L-band + reference link

- **Suitable for all modulation formats**
- **Ultra-wide dynamic range**
- **Negligible intermodulation**
- **SNMP and web interface for remote monitoring and control**
- **Multiple carrier transmission**

RF + reference over a single fibre

The **ViaLiteHD** L-band + reference link is designed for applications where remote equipment shares a common frequency reference – typically 10MHz – however the link will support reference signals in the range 5-20MHz.

- Reference and traffic signals are transported on different wavelengths to minimise intermodulation
- Requires only a single fibre
- Reference can be supplied on a single RF connection with the carrier signal or from separate input sources
- A multiplexed signal can be connected to the BUC/amplifier or demultiplexed and supplied to two separate RF connections
- Receive path link also available

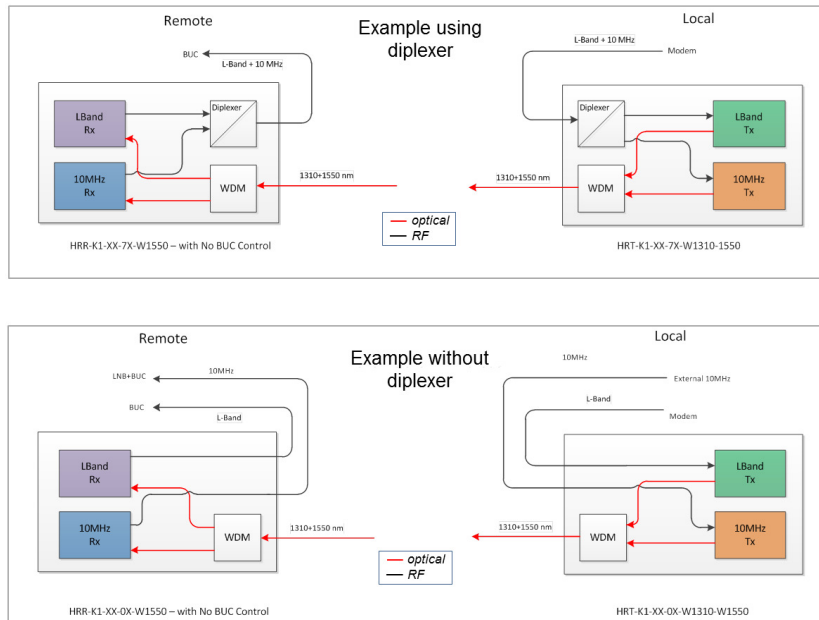

ViaLiteHD fibre optic links are available as rack mounted cards, small form factor modules and Edge OEM modules.

A fully populated 19" 3U **ViaLiteHD** rack supports up to 26 links and accepts 13 RF cards plus an SNMP card and dual power supply modules. A 1U chassis accepts three RF cards or two RF cards plus an SNMP card.

Small form factor modules offer a compact, single link solution and Edge OEM modules allow system integrators and equipment manufacturers to build RF/optical interfaces into their own design. A range of support modules and accessories including indoor rack equipment and weatherproof outdoor enclosures is also available.

RF Performance Characteristics

	L-Band	Reference	L-Band	Reference
Impedance	50 ohms, duplexed		75 ohms, duplexed	
Frequency range	950 - 2150 MHz	5-20 MHz	950 - 2150 MHz	5-20 MHz
Flatness	± 1.5 dB (max) ^{a,d} ± 0.5 dB (typical) ^{a,d} ± 0.2 dB in any 36 MHz ^{a,t}	± 0.5 dB (typical) ^{a,d}	± 1.5 dB (max) ^{a,d} ± 0.8 dB (typical) ^{a,d} ± 0.2 dB in any 36 MHz ^{a,t}	± 0.5 dB (typical) ^{a,d}
VSWR (50 Ohm)	1:1.5 ^t		1:1.5 ^t	
IMD	-62 dBc ^{t,c}	-	-50 dBc ^{t,c}	-
CNR	57 dB ^b	-	55 dB ^b	-
Test input / output signal	-20 dBm	0 dBm	-20 dBm	0 dBm
Maximum input power	+15 dBm (without damage)		+15 dBm (without damage)	
Gain stability	0.25 dB over 24 hours		0.25 dB over 24 hours	
RF link gain (nominal)	+9 dB ^a	0 dB ^a	+3 dB ^a	0 dB ^a
Input IP3(at default gain)	+12 dBm ^{t,c}	-	+12 dBm ^{t,c}	-
P1dB (at default gain)	0 ^t dBm	+10 dBm	0 dBm	+4 dBm
Noise figure(at default)	20 dB ^{t,a}	34 dB ^{t,a}	22 dB ^{t,a}	34 dB ^{t,a}
LNB power (optional)	Internal 13/18V @ 700mA, with switchable tone		Internal 13/18V @ 700mA, with switchable tone	
SFDR	110 dB Hz 2/3 ^{t,a}	-	109 dB Hz 2/3 ^{t,a}	-
Reference sidebands	55 dBc ^t	-	50 dBc ^t	-

Optical Performance Characteristics

	L-Band	Reference
Laser type	DFB	DFB
Optical wavelength	1550 nm ± 20 nm	1310 nm ± 20 nm
Optical power output	3.5 dBm (nominal)	3.5 dBm (nominal)
Optical connector	SC/APC (E2000/APC and FC/APC options)	SC/APC (E2000/APC and FC/APC options)

Temperature Characteristics

	L-band + 10MHz Link
Operating temperature	-20°C to +50°C
Storage temperature	-40°C to +70°C

Part Numbering and options

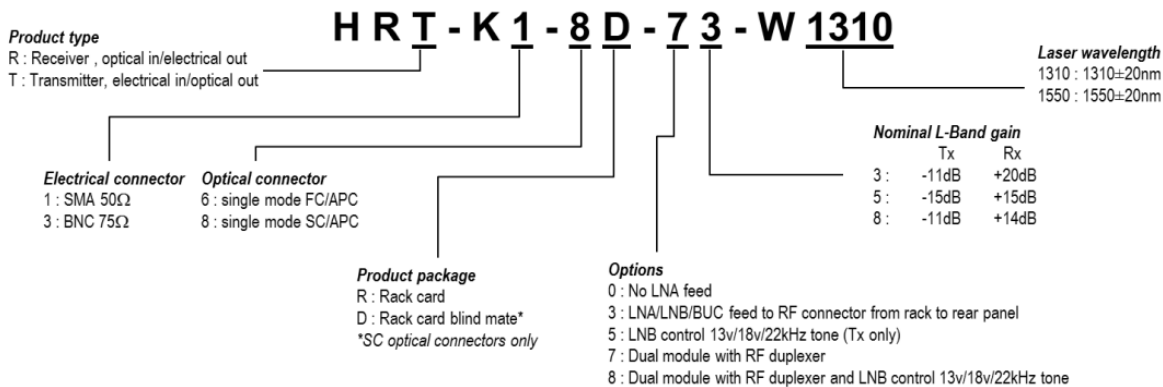

Mechanical Dimensions

