

6RU Rack Mountable GaAs Solid State Power Amplifier



1.1 kW C-Band High Power SSPA

FEATURES

- Extremely High Power Density:
to 1.1 kW C-Band;
to 1000W X-Band;
to 500W Ku-Band.
- Hot Swap, n+1 Redundant Power Supply
- Power Factor Corrected Power Supply
- Modular (soft-fail) Architecture
- Front Panel Touchscreen
- Removable fan assemblies
- Ethernet Port
- RF Output Sample Port
- Built-in 1:1 Redundancy Control
- Built-in Maintenance Switch Controller

OPTIONS

- Extended Frequency Band
- L-Band Input operation
- Reflected Power Monitor
- Phase Combined Systems
- Remote Control Panel
- RF Input Sample Port
- Rear Panel Exhaust

SPECIFICATIONS

- SSPA Chassis housing:
19.0 X 10.47 X 30.25 in
483 X 266 X 768 mm
180 lbs. / 82 kg
- 1RU Power Supply:
19.0 X 1.75 X 16.30 in
483 X 45 X 414 mm
33 lbs. / 15 kg
- Gray powder coat finish
- Operating temperature:
0 to +50 °C

DESCRIPTION

Teledyne Paradise Datacom's Indoor, High Power Rack Mount (R) series SSPAs represent the industry's highest power density and most reliable high power amplifier systems. These high power amplifiers are accompanied with a separate 1RU power supply chassis.

The power supply is configured as a n+1 redundant, hot swappable power supply comprised of up to four modules. The power supply is populated with one module more than needed to power the HPA. In the event of a single power supply module failure, the amplifier system will not fail. The power supply module can be changed without ever taking the HPA out of service. The microwave amplifier architecture is also designed for maximum soft fail redundancy.

The High Power Rack Mount SSPA employs a modular design, which allows quick and easy replacement in the event of a catastrophic failure of one of the SSPA components. These modular assemblies include: front and rear fan trays; and a rear panel controller card.

Specifications, C-Band SSPAs

PARAMETER	NOTES	LIMITS	UNITS
Frequency Range	Frequency selection "A" Frequency selection "B" ¹ Frequency selection "C" Frequency selection "E" Frequency selection "F" Frequency selection "G"	5.850 to 6.425 5.850 to 6.725 5.750 to 6.670 6.425 to 6.725 6.725 to 7.025 5.750 to 6.475	GHz GHz GHz GHz GHz GHz
Output Power Typical, P _{sat} Guaranteed minimum, P _{1dB}	HPAC6800ARXXXXP HPAC6900ARXXXXP HPAC611KARXXXXP	P_{sat} / P_{1dB} 59.0 (800) / 58.0 (630) 59.5 (900) / 58.5 (700) 60.4 (1100) / 60.0 (1000)	dBm (W) dBm (W) dBm (W)
Power Requirements Line Frequency Line Power (Voltage) (typical @ 220 VAC)	power factor HPAC6800ARXXXXP HPAC6900ARXXXXP HPAC611KARXXXXP	.98 47 to 63 4150 (180 to 265) 4850 (180 to 265) 6000 (180 to 265)	Hz W (VAC) W (VAC) W (VAC)

Note 1: De-rate output power by 1 dB linearly from 6.425 to 6.725 GHz.

Specifications, X-Band SSPAs

PARAMETER	NOTES	LIMITS	UNITS
Frequency Range	Frequency selection "A" Frequency selection "B" Frequency selection "C" Frequency selection "D" ¹	7.90 to 8.40 7.50 to 8.50 9.50 to 10.50 7.70 to 8.40	GHz GHz GHz GHz
Output Power Typical, P _{sat} Guaranteed minimum, P _{1dB}	HPAX6700ARXXXXP HPAX610KARXXXXP	P_{sat} / P_{1dB} 58.5 (700) / 58.1 (650) 60.0 (1000) / 59.5 (900)	dBm (W) dBm (W)
Power Requirements Line Frequency Line Power (Voltage) (typical @ 220 VAC)	power factor HPAX6700ARXXXXP HPAX610KARXXXXP	.98 47 to 63 5500 (180 to 265) 6000 (180 to 265)	Hz W (VAC) W (VAC)

Note 1: De-rate output power by 1 dB linearly from 7.90 to 7.70 GHz.

Specifications, Ku-Band SSPAs

PARAMETER	NOTES	LIMITS	UNITS
Frequency Range	Frequency selection "A" Frequency selection "B" ¹	14.00 to 14.50 13.75 to 14.50	GHz GHz
Output Power Typical, P _{sat} Guaranteed minimum, P _{1dB}	HPAK6400ARXXXXP HPAK6500ARXXXXP	P_{sat} / P_{1dB} 56.0 (400) / 55.0 (316) 57.0 (500) / 56.0 (400)	dBm (W) dBm (W)
Power Requirements Line Frequency Line Power (Voltage) (typical @ 220 VAC)	power factor HPAK6400ARXXXXP HPAK6500ARXXXXP	.98 47 to 63 4600 (180 to 265) 5100 (180 to 265)	Hz W (VAC) W (VAC)

Note 1: De-rate output power by 1 dB linearly from 14.00 to 13.75 GHz.

General Specifications: 6RU RM Series

PARAMETER	NOTES	LIMITS	UNITS
Gain	minimum	75	dB
Gain Flatness	full band	± 1.0	dB
	Extended C-Band units	± 1.5	dB
Gain Slope	per 40 MHz	± 0.3	dB/40 MHz
Gain Variation vs. Temperature	0 °C to +50 °C	± 1.0	dB
Gain Stability	at constant temperature	± 0.25	dB/24 hours
Gain Adjustment	0.1 dB resolution	20	dB
Intermodulation Distortion	3dB back off relative to P _{1dB}	-25	dBc
AM/PM Conversion	(@ rated P _{1dB})	3.5	°/dB
	(@ P _{1dB} - 3 dB)	0.5	°/dB
Spurious Harmonics	(@ rated P _{1dB})	-65	dBc
	(@ rated P _{1dB} - 3 dB)	-50	dBc
Input/Output VSWR	All units except Extended C-Band Extended C-Band units ¹	1.30:1 1.50:1	
Noise Figure	at maximum gain	12	dB
Group Delay (per 40 MHz segment)	Linear	0.01	ns/MHz
	Parabolic	0.003	ns/MHz ²
	Ripple	1.0	ns p-p
Noise Output	TX Band	-75	dBW/4 KHz
	RX Band (C- or Ku-Band)	-150	dBW/4 KHz
	RX Band (X-Band)	-100	dBW/4 KHz
Output Isolation	@ full reflected power	25	dB
Residual AM Noise	0 - 10 KHz	-45	dBc
	10 KHz - 500 KHz	-20 (1.25 + log F)	dBc
	500 KHz - 1 MHz	-80	dBc
Phase Noise		IESS -308/309 - 10 dB	

Mechanical

Size			
HPA Chassis (6RU)	width X height X depth	19.0 X 10.47 X 30.25 483 X 266 X 768	inches mm
Power Supply Chassis (1RU)	width X height X depth	19.0 X 1.75 X 16.30 483 X 44 X 414	inches mm
Weight			
HPA Chassis		180 (82)	lbs.(kg)
Power Supply Chassis (1RU)	Chassis plus four (4) modules	33 (15)	lbs.(kg)
Finish		powder coat	Gray

Environmental

Operating Temperature	Ambient	0 to +50	°C
Operating Relative Humidity	Non-condensing	95	%
Operational Altitude	Above sea level	10,000 (3,048)	ft. (m)
Storage Temperature	Ambient	-20 to +75	°C
Storage Relative Humidity	Non-Condensing	90	%
Cooling System	Integrated	Forced air	

L-Band Operation

Teledyne Paradise Datacom amplifiers are available with an integrated L-Band Block Up Converter. L-Band units utilize Teledyne Paradise Datacom's proprietary zBUC technology. The addition of a zBUC® converter to the SSPA typically increases the gain by 2-4 dB. The advantages of zBUC technology include:

- zBUC converter can detect and switch to an externally supplied reference.
- Optional internal high stability (10MHz) reference.
- zBUC converter can lock to an externally supplied reference of 10 MHz or 50 MHz.
- zBUC converter can accept a wide range of external reference power (-10 to +5 dBm).

Available Frequency Plans

Band	Frequency Band	IF Input	LO Frequency	RF Output	Gain Change
C	Sub-Band "A"	950 - 1525 MHz	4.900 GHz	5.850 - 6.425 GHz	0-4 dB
C	Sub-Band "B"	950 - 1825 MHz	4.900 GHz	5.850 - 6.725 GHz	0-4 dB
C	Sub-Band "C"	950 - 1870 MHz	4.800 GHz	5.750 - 6.670 GHz	0-4 dB
C	Sub-Band "E"	950 - 1250 MHz	5.475 GHz	6.425 - 6.725 GHz	0-4 dB
C	Sub-Band "F"	950 - 1250 MHz	5.775 GHz	6.725 - 7.025 GHz	0-4 dB
C	Sub-Band "G"	950 - 1675 MHz	4.800 GHz	5.750 - 6.475 GHz	0-4 dB
X	Sub-Band "A"	950 - 1450 MHz	6.950 GHz	7.900 - 8.400 GHz	0-2 dB
Ku	Sub-Band "A"	950 - 1450 MHz	13.050 GHz	14.00 - 14.50 GHz	0-2 dB
Ku	Sub-Band "B"	950 - 1700 MHz	12.800 GHz	13.75 - 14.50 GHz	0-2 dB

Electrical Specifications for 6RU RM SSPA with ZBUC converter

PARAMETER	NOTES	LIMITS				UNITS
Gain	Nominal setting	75				dB
Gain Flatness	full band (C-,X-,Ku-bands)	± 2.0				dB
Gain Slope	per 40 MHz (C-,X-,Ku-bands)	± 0.5				dB/40 MHz
Gain Adjusted Range		20				dB
	Typical C-Band Adj. Range	60 - 80				dB
	Typical Ku-Band Adj. Range	57 - 77				dB
Gain Stability	-40 to +60 °C	± 1.5				dB
Phase Noise	Offset frequency from carrier	<u>Absolute max.</u>	<u>C-band (typ.)</u>	<u>X-band (typ.)</u>	<u>Ku-band (typ.)</u>	
	10 Hz	-30	-60	-58	-56	dBc/Hz
	100 Hz	-60	-74	-70	-67	dBc/Hz
	1 KHz	-70	-84	-80	-78	dBc/Hz
	10 KHz	-80	-100	-94	-91	dBc/Hz
	100 KHz	-90	-105	-97	-94	dBc/Hz
	1 MHz	-90	-125	-122	-120	dBc/Hz
Spurious	In-Band Signal Related (C-/Ku-Band) (Extended C-Band)	-50				dBc
	Close to Carrier Spurious (≤ 20 MHz)	-40				dBc
	Local Oscillator	-50				dBc
		-30				dBm
Noise Figure	At Maximum gain	20				dB
Transmit Band Noise Output Power Density	Tx Band at Maximum gain	-65				dBW/4kHz
Input VSWR	L-Band	1.5 : 1				
Internal Reference Option	Reference Accuracy (initial)	± 1 • 10 ⁻⁸				
	Aging per day (after 30 days)	± 1 • 10 ⁻⁹				
	Aging per year (after 30 days)	± 6 • 10 ⁻⁸				
	Reference Stability over Temperature (-40 to +40 °C, ambient)	± 1 • 10 ⁻⁸				

6RU Rack Mountable GaAs Solid State Power Amplifier

Power Supply

The 6RU Chassis is offered with a 1RU power supply which houses up to four (4) 2.5 kW power supply modules, giving N+1 redundancy on the input power for the amplifier.

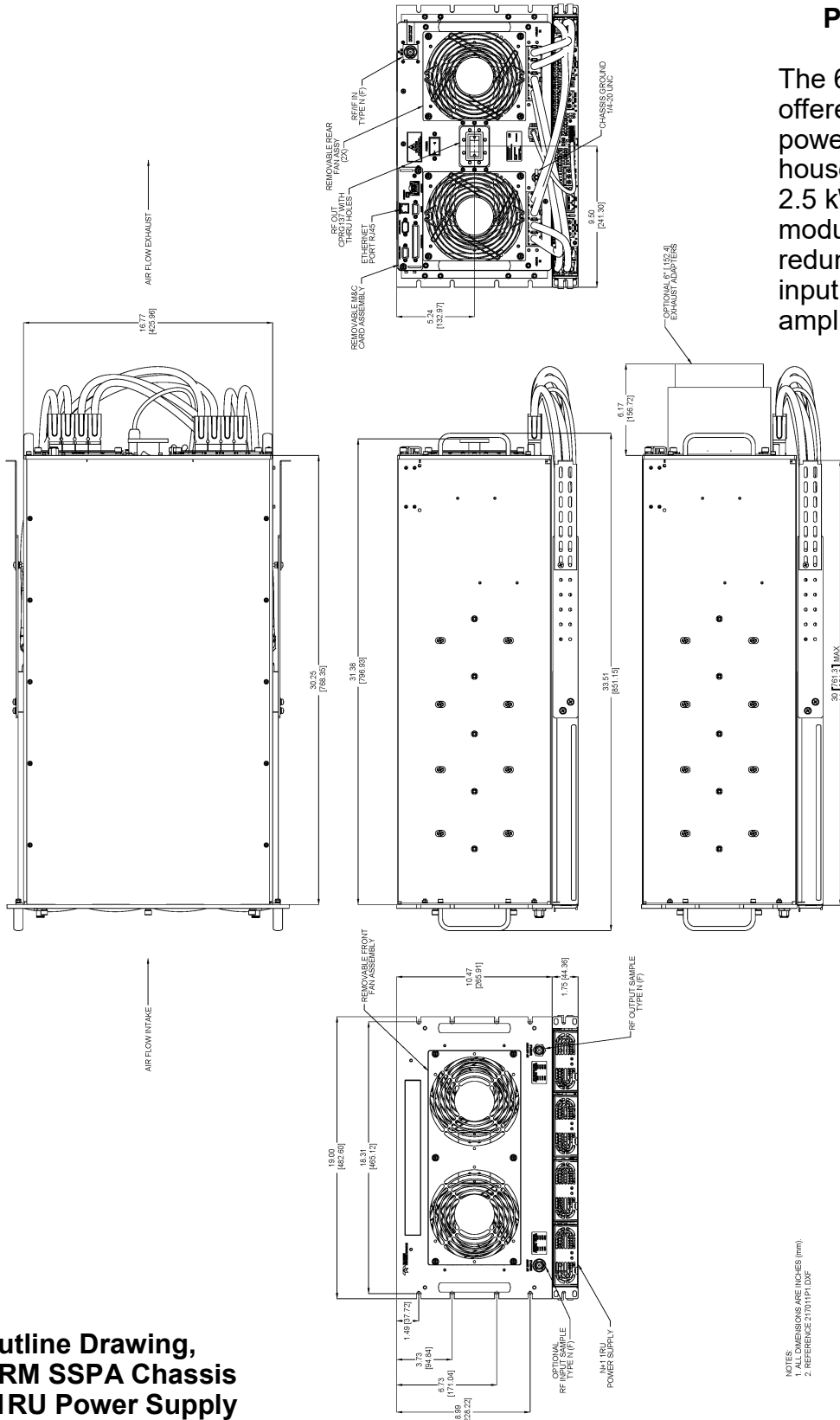

**Outline Drawing,
 6RU RM SSPA Chassis
 and 1RU Power Supply**

NOTES:
 1. DIMENSIONS ARE IN INCHES (mm).
 2. REFERENCE 217011P1.DXF

6RU Rack Mountable GaAs Solid State Power Amplifier

Part Number Configuration Matrix

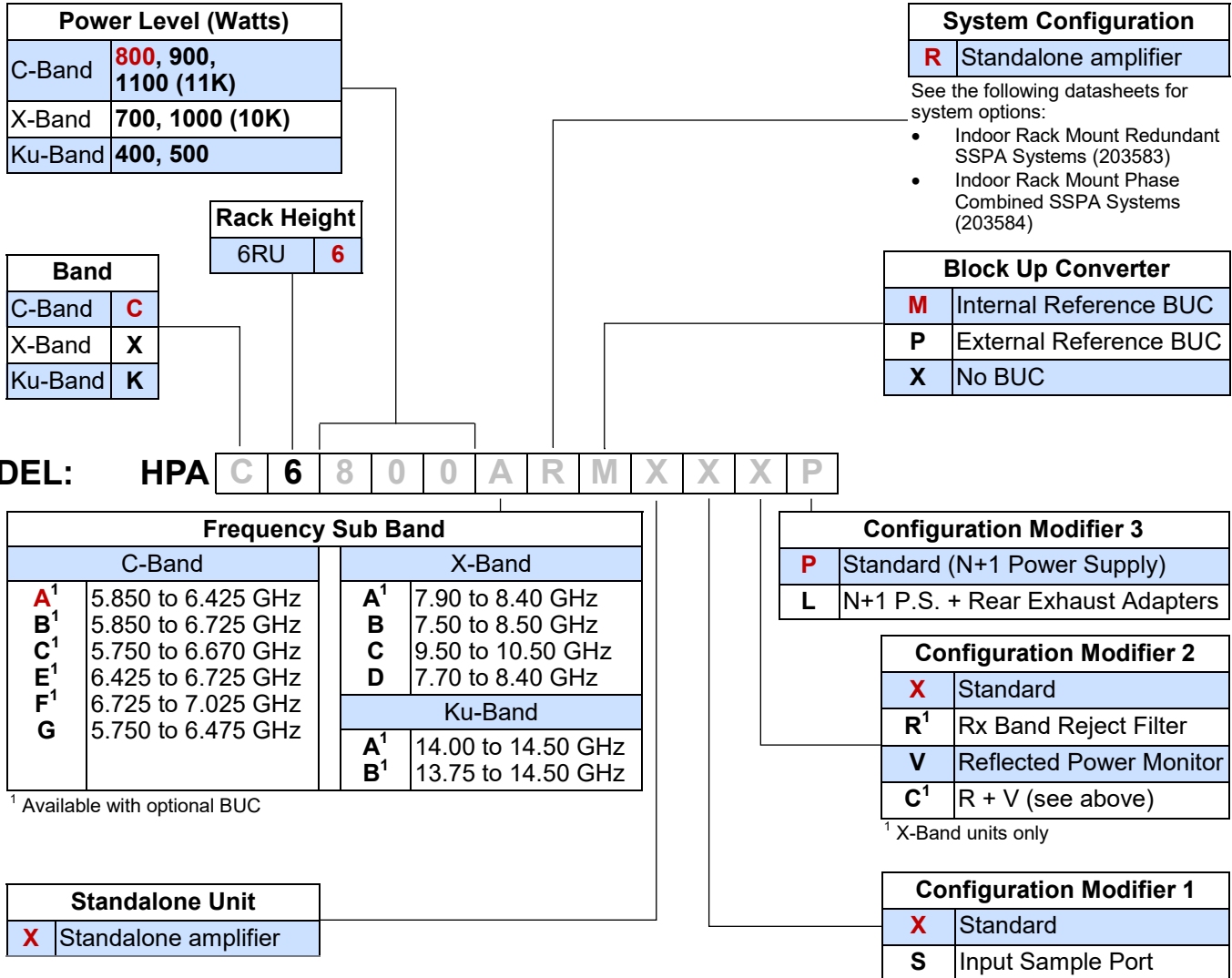

Example - A standalone 800W GaAs C-Band 6RU Rack Mount SSPA with standard N+1 external power supply and an optional internal reference block up converter is part number: **HPAC6800ARMXXXP**.

Use and Disclosure of Data

Information contained herein is classified as EAR99 under the U.S. Export Administration Regulations. Export, reexport or diversion contrary to U.S. law is prohibited.

Proprietary and Confidential

The information contained in this document is the sole property of Teledyne Paradise Datacom. Any reproduction in part or as a whole without the written permission of Teledyne Paradise Datacom is prohibited.

Specifications are subject to change without notice.