

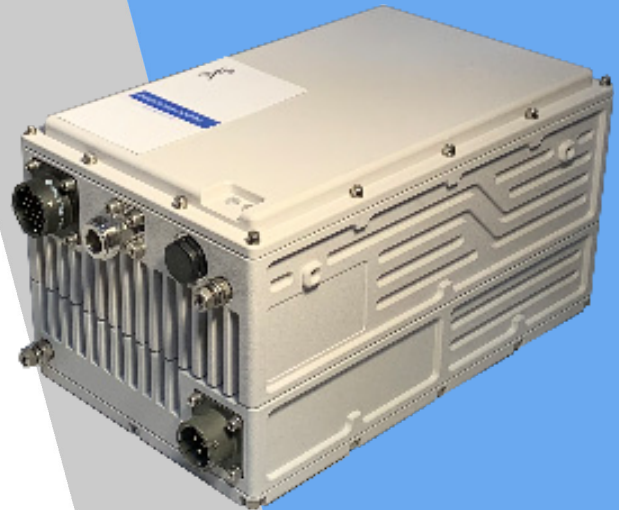

Amkom APKU125 125W Ku-Band BUC Datasheet

Features:

- ◆ Robust, Light Package Design Only 9.2lbs (4.2kg)
- ◆ Extreme Stability, Reliability and Performance
- ◆ Built-in HPA Overdrive Circuit Protection
- ◆ High Temperature Mode - up to + 70°C
- ◆ Built-in Optimized Linearization
- ◆ Built-in Receive Band Reject Filter
- ◆ Built-in Anti Vibration Technology
- ◆ Extreme GaN Linearity and Efficiency
- ◆ Exceeds ALL IESS-308/309 Phase Noise Standards
- ◆ Triple protection sealed waveguide output
- ◆ Field Replaceable IP68 150,000 hr Rated Fans
- ◆ Assembled and Rigorously Tested in California
- ◆ 3 Year Warranty



Design Overview:

The P for "PHANTOM" series Extended (13.75 - 14.5GHz) and Standard (14.0 - 14.5GHz) Ku-Band BUCs are the next generation of the World's Most efficient and compact size BUCs in the industry, weighing only 9.2lbs (4.2kg) and handling output power of 125W (min) at the Ku-Band frequencies. We've picked the best of both worlds as we implemented the most mature, proven efficient and reliable GaAs + GaN High Power Amplifiers with internal overdrive protection and precise linearization technique. We've chosen an absolute and "No Corner Cutting" concept in our design. Its weatherproof and robust Hyper-Light package is constructed with the most advanced mechanical precision engineering in mind. We've taken absolutely no compromises during each of the design stages using only the toughest aerospace grade aluminum based metal with the most efficient heat disposal properties. Each unit is vigorously tested at our California facility according to our ATP (acceptance testing procedure).

TECHNICAL SPECIFICATIONS

Operating RF Frequency	13.75-14.5 GHz 14.0-14.5 GHz 12.75 -13.25 GHz
Operating IF frequency	950-1700 MHz 950-1450 MHz 950-1450 MHz
Local Oscillator (Fixed)	12.80 GHz 13.05 GHz 11.80 GHz
Rated Output Power Linear Power SR @ -26dBc	125W 51 dBm PSAT (min) 100W 50 dBm PLIN (typ)
IF Connector	N-type (50 Ohm) F-type (75 Ohm)
Prime Power via MS Connector	+ 85-260 VAC 590W PSAT & 470W @ P-LINEAR SR
10MHz External Ref. (Internal High Stability Optional)	10MHz Reference Level: 0dBm +/- 5dBm
Output Interface	WR75 Sealed & Grooved
Gain (Temperature Compensated)	75dB(min) 80 dB(typ.)
TX Gain variation 50MHz	± 0.5 dB
TX Gain variation 500MHz	± 1.5 dB
Built-in Receive Reject Filter	Suppression by +20 dB (min.)
Stealth Linear operation mode (optional)	LED Shut-Off Silenced fans
TX Gain Flatness	± 0.75 dB max. over 40 MHz
IMD3 (two tones) 3dB off Rated Power (typical)	-25 dBc max. 2 signal 5MHz apart at P-LINEAR
In-Band/Out-band Spurious	-60dBc max.
Input VSWR	1.5:1
Output VSWR	1.5:1
Spectral Regrowth at P _{LINEAR} (QPSK at 1.5x and OQPSK at 1.0x symbol rate off-set with 2dB back-off from rated power)	-30 dBc
Group Delay	Ripple 1 nsec point to point max.
AM/PM Conversion	1.0°/dB max. at 3 dB output backoff
Noise Power Density (TX)	-85dBm/Hz
Noise Power Density (RX)	-155dBm/Hz (10.95 - 12.75 GHz)
Phase Noise (Up Converter) (Ext. Ref.)	-55 dBc/Hz @ 10 Hz -115dBc/Hz -65 dBc/Hz @ 100 Hz -135dBc/Hz -75 dBc/Hz @ 1 kHz -150dBc/Hz -85 dBc/Hz @ 10 kHz -155dBc/Hz -95 dBc/Hz @ 100 kHz -160dBc/Hz
Monitor & Control	Ethernet Web Page Based, RS232/485
Environmental MIL-STD Vibration MIL-STD	Compliant with MIL-STD810E MIL-STD810F, Method 514.5 C-2 Transport
Operating Temperature Range	- 40° C to + 70°C
Storage Temperature Range	- 60°C to + 85°C
Fan Rating / Field Replaceable	IP 68, Field Interchangeable
Humidity	100% Condensing, IP67 Rated
Shock	20 g peak, 11 msec, 1/2 sine
Altitude	21,500ft, 6,500m
Dimensions	8.5" x 5.2" x 4.54" (215x132x114 mm) Measurements without connectors
Weight	9.2lbs (4.2kg)

MECHANICAL DRAWING

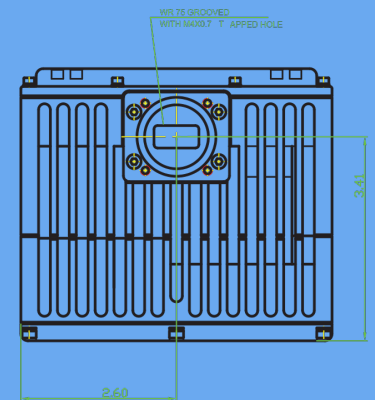
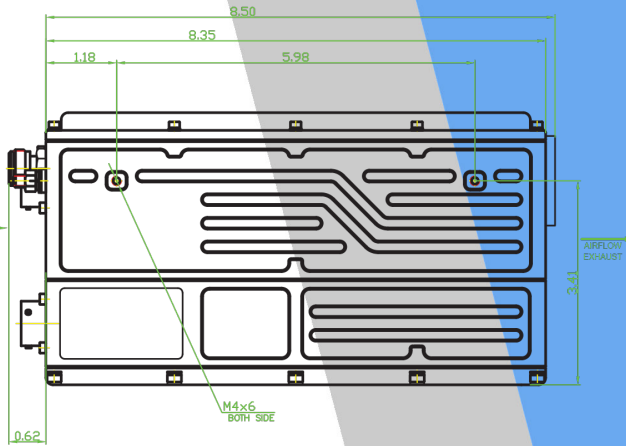
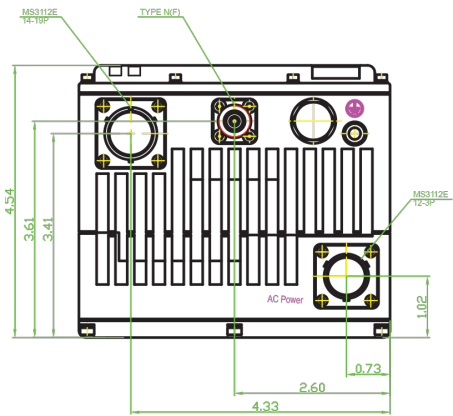
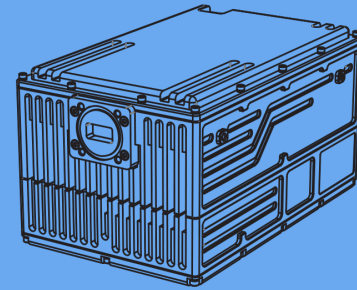
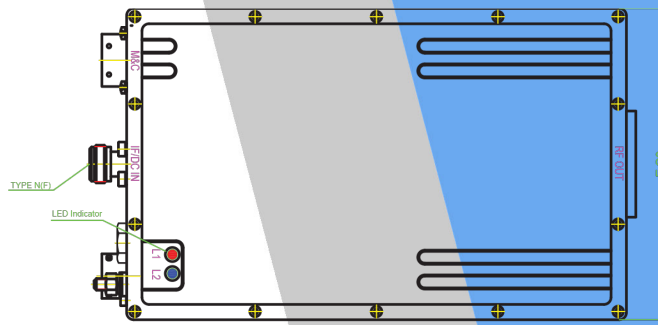

PART NUMBERING SYSTEM

AP - "PHANTOM" MODEL SERIES

KU - Universal Ku-Band 13.75 - 14.50 GHz

KS - Standard Ku-Band 14.0 - 14.50 GHz

KL - Low Ku-Band 12.75 - 13.25 GHz

125 - Rated Power in Watts

N - 50 Ohm IF Input Connector Type | **F** - 75 Ohm IF Input Connector Type

A - VAC +85-260 Power Supply built-in

M - M&C Option - RS232/485 + Ethernet

R - 10 MHz Ref. Auto Sense | Internal Reference

C - Custom option availability

Example: APKU125NAMR