

The IRT Technologies Intelligent Frequency Converters (IFC™) shape the next-generation satellite transmission with its breakthrough leading edge technology, state of the art design, and unprecedented reliability with 3 years warranty for this product line!

Features patent pending hot-swappable power supply and converter module shelf redundancy with embedded switch controller, embedded input and output switches and extensive monitor & control via front panel, serial ports EIA232/EIA485 and Ethernet.

IFC™ Series features Best in Class RF characteristic, Flexible reference with autosensing can lock to external 5/10 MHz reference or utilize built-in high stability reference oscillator.

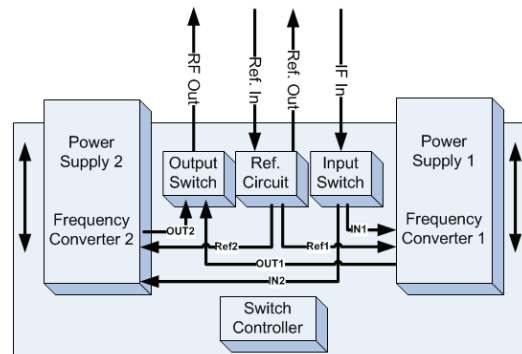

KEY FEATURES

- 1:1 Redundant patent pending real hot swappable in 1RU chassis with no need for additional external 1RU switch controller and external input/output switches
- Superior RF performance:
 - Phase noise 8dB better than IESS308/309
 - In Band Spurious below -60dBc
 - Superior Gain flatness
- Only two frequency options covering full Ku-Band (receive or transmit)
- User Friendly front panel with menu driven display
- 5/10MHz external reference Autosense
- Full featured M&C Interface via serial EIA485, EIA232 and Ethernet:
 - Frequency control with 1kHz step
 - 20dB Gain Control
 - Input and output power detectors
 - Automated level control (ALC) mode optional
- External Redundant Interface for higher level redundancy capability
- IF and RF monitoring optional
- 48VDC isolated power supply optional



IFC™ SERIES IF TO KU-BAND UP/DOWN CONVERTER 1:1 REDUNDANCY RACK MOUNT SYSTEM

IFC™ SERIES IF- TO KU-BAND UP/DOWN CONVERTER RACK MOUNT SYSTEM SPECIFICATION

	UPCONVERTER	DOWNCONVERTER
IF CHARACTERISTICS	IF Input	IF Output
Frequency Range:		
70MHz IF	70MHz +/-18MHz	
140MHz IF	140MHz +/-36MHz	
Output Power @P1dB	N/A	5dBm min
Max Input Level	10dBm	N/A
Impedance	50Ohm/75Ohm optional	
Return Loss	-18dB max	
RF CHARACTERISTICS	RF Output	RF Input
Frequency Range: Opt. 1	14-14.5GHz	10.7-11.7GHz
Opt. 2	13.75-14.5GHz	11.7-12.75GHz
Opt. 3	N/A	10.7-12.75GHz
Frequency Step	1kHz/1Hz	
Output Power @P1dB	15dBm min	N/A
2 tone IMD at 0dBm Pout	-36dBc max	N/A
Gain Control	20dB range 0.1dB step	
10MHz Ref Out (Optional)	Separate Connector	
Impedance	50Ohm/75Ohm optional	
Return Loss	1.5	
Max Input Level	N/A	Operational up to 0dBm No Damage up to 10dBm
TRANSFER CHARACTERISTICS		
Conversion Gain	30 dB (Optional 35 dB)	
Gain Adjustment	20dB with 0.1dB step(Optional 25 dB)	
Gain Flatness 70MHz IF:	+/-0.5dB	
over full C- band:	+/-1.0 max	
over 36MHz:	+/-0.5 max	
Phase noise: @ 100Hz	-68dBc	
@ 1kHz	-78dBc	
@ 10kHz	-88dBc	
@ 100kHz	-95dBc	
@ 1MHz	-115dBc	
In Band Spurious	<-60dBc	
REFERENCE		
Frequency	10MHz	5MHz Optional
Int./Ext. Autosense	Int. clock locks on external reference	
Frequency Stability		
Short term	0.01 ppb	
Aging	+/-100ppb per year	
Phase Noise @ 10Hz	-125dBc/Hz	
@ 100Hz	-140dBc/Hz	
@ 1kHz	-150dBc/Hz	
@ 10kHz	-155dBc/Hz	
Power at 10M out port	+5dBm+/-2dB Optional	

MONITOR & CONTROL FEATURES	
Interfaces:	
Serial - EIA485	DB9 Connector rear panel
Serial - EIA232	RJ45 or DB9 Connector rear panel
10/100 base-T Ethernet	RJ45 Connector rear panel
Alarm and Control	DB9 Connector rear panel
Redundant protection interface	HD15 Connector rear panel
Controls:	
Gain Control	via Serial, Ethernet, Front panel
Uplink/Downlink Freq Control	via Serial, Ethernet, Front panel
Mute Control	via Serial, Ethernet, Fr. panel, Red Int.
A/B Redundancy Toggle	via Serial, Ethernet, Front panel,
Local/Remote toggle	Serial(Ethernet)/Front panel toggle
Auto/Manual toggle	via Serial, Ethernet, Front panel,
Clear Alarm	via Serial, Ethernet, Front panel
Indicators:	
Uplink/Downlink Frequency	via Serial, Ethernet, Front panel
Gain Status	via Serial, Ethernet, Front panel
IF&RF Power Detect	via Serial, Ethernet, Front panel
Temperature	via Serial, Ethernet, Front panel
Active/Stand by status	via Serial, Ethernet, Front panel
Switch Position	via Serial, Ethernet, Front panel
Summary Alarm Status	via Serial, Ethernet, Front panel, Redundancy Interface
Mute Status	via Serial, Ethernet, Front panel, Redundancy Interface
POWER SUPPLY	
Input Voltage	90 to 265VAC 50/60Hz PFC
	48VDC Isolated Optional
MECHANICAL	
Width	19" Rack
Height	1RU
Depth	20"
Color	Metallic
Cooling	Forced air
IF/RF CONNECTORS	
IF	BNC (other options available)
RF	N-type (other options available)
10MHz Ref In/Out	BNC (other options available)
IF Monitoring (Optional)	BNC (other options available)
Ku-Band Monitoring (Optional)	N-type (other options available)
ENVIRONMENTAL	
Operating temperature	0 to 60 deg.C
Storage Temperature	-40 to +85 deg.C
Humidity	0 to 95% (non-condensing)