

4.9 Meter ESA

Like all CPI Antenna Systems Division earth station antennas, the 4.9 Meter Earth Station Antenna provides high gain and exceptional pattern characteristics.

This antenna system is designed to address the stringent requirements of both the television broadcast industry and telecommunications network operators who demand unsurpassed flexibility and electrical performance in high-quality, cost-effective, and reliable packages.

The electrical performance and exceptional versatility provides the ability to configure the antenna with your choice of linearly- or circularly- polarized 2- or 4- port combining networks. That versatility is provided at the time of initial purchase, as well as in the future, as your satellite communication requirements evolve.

This antenna system is used worldwide in broadcast applications and high density data, voice and communications networks. The CPI Antenna Systems Division 4.9 meter earth station antenna features a computer-optimized dual reflector Gregorian optics system and close-tolerance manufacturing techniques.

This combination provides extremely accurate surface contour resulting in exceptionally high gain and closely controlled pattern characteristics. CPI Antenna Systems Division earth station antennas provide maximum durability with minimal maintenance.



Features

- Self-aligning main reflector - no optical field alignment
- 3 year warranty on all structural components
- FCC paragraph 25.209 for mandatory pattern requirements for 2 degree satellite spacing based on off satellite measurement at Ku- Band
- Configured for C-, X-, Ku-, K- and Ka- Band transmit and receive
- Low PIM Capabilities

24/9 Powells Road, Brookvale,
New South Wales 2100, Australia

+61 (02) 9939 4377

info@avcomm.com.au



4.9 Meter ESA

Design Standards

| | |
|--------------|---|
| Reflector | Aluminum painted with highly diffusive white paint |
| Ground Mount | Hot-dipped galvanized steel, per ASTM-A123 for structural steel. |
| Hardware | Sizes ≤ 3/8 in (9.5mm), stainless steel, passivated per MIL-F-14072-E300 Sizes ≥ 3/8 in (9.5mm), hot-dipped galvanized stainless steel, passivated per ASTM-A123 |

Environmental Performances

| | |
|------------------------|--|
| Operating Temperature | -40° to 52°C (-40° to 125°F) |
| Seismic (Earthquake) | 1 G Vertical and Horizontal acceleration. Equivalent to a Richter Magnitude 8.3, and Grade 11 on the modified Mercalli Scale |
| Operational Winds | 45 mph (72 km/h) Gusts to 65 mph (105 km/h) |
| Survival Winds | 125 mph (200 km/h) in any position of operation |
| Rain | 4 in (102 mm) per hour |
| Solar Radiation | 360 BTU/hr/ft ² (1135 Watts/m ²) |
| Relative Humidity | 100% |
| Shock and Vibration | As encountered by commercial Air, Rail and Truck shipment. |
| Atmospheric Conditions | As encountered by Moderately Corrosive Coastal and Industrial Areas. |

Mechanical Performances

The 4.9m Antenna mechanical general specifications and performances are listed in below table. Additional information, dimensions and layout may be provided by CPI Antenna Systems Division on a case-by-case basis.

| | |
|--------------------|----------------------------|
| Optics Type | Dual Reflector Gregorian |
| Reflector Material | Precision-Formed Aluminum |
| Reflector Segments | 12 |
| Mount Type | EI over Az, Pedestal Mount |

| Antenna Pointing Range, Coarse/(Continuous) | |
|---|-------------|
| Elevation: | 0-90° (90°) |
| Azimuth: | 360° (120°) |
| Polarization | (180°) |

| Hub/Enclosure Dimensions | |
|--------------------------|---------------|
| Diameter | 1.32m (52 in) |
| Depth | 0.81m (32 in) |

Shipping Information

| Packing Options | |
|--|--------------------|
| Standard Commercial Domestic Pack | Included |
| Ocean Export Pack - For non-containerized, packed for seal against salt water spray | OCEANSHIP-MD |
| Air Export Pack - For freighter aircraft shipments. Lower deck AirPack requires specialized bids | AIR EXPORT PACK-MD |
| Container Packaging | CNTPCK-MD |

| Required Shipping Container | |
|-----------------------------------|------------|
| Standard 20 ft land/sea container | Quantity 1 |

Shipping container information is given for basic configuration and may vary depending on the selected options, please contact CPI Antenna Systems Division for specific container loading plan.

24/9 Powells Road, Brookvale,
 New South Wales 2100, Australia
 +61 (02) 9939 4377
 info@avcomm.com.au

4.9 Meter ESA

Dimensional Drawings

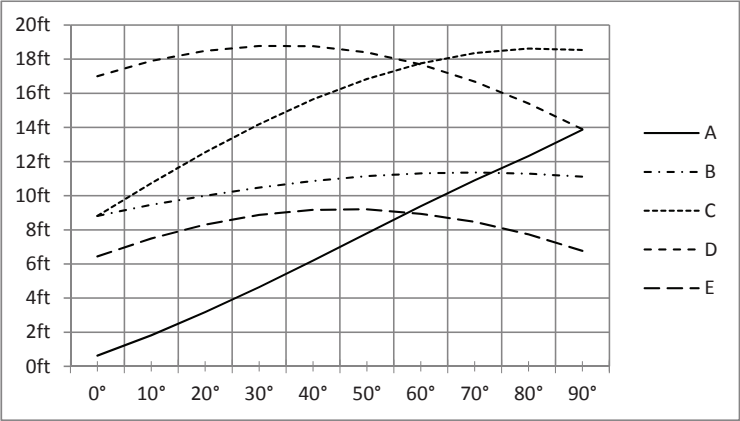
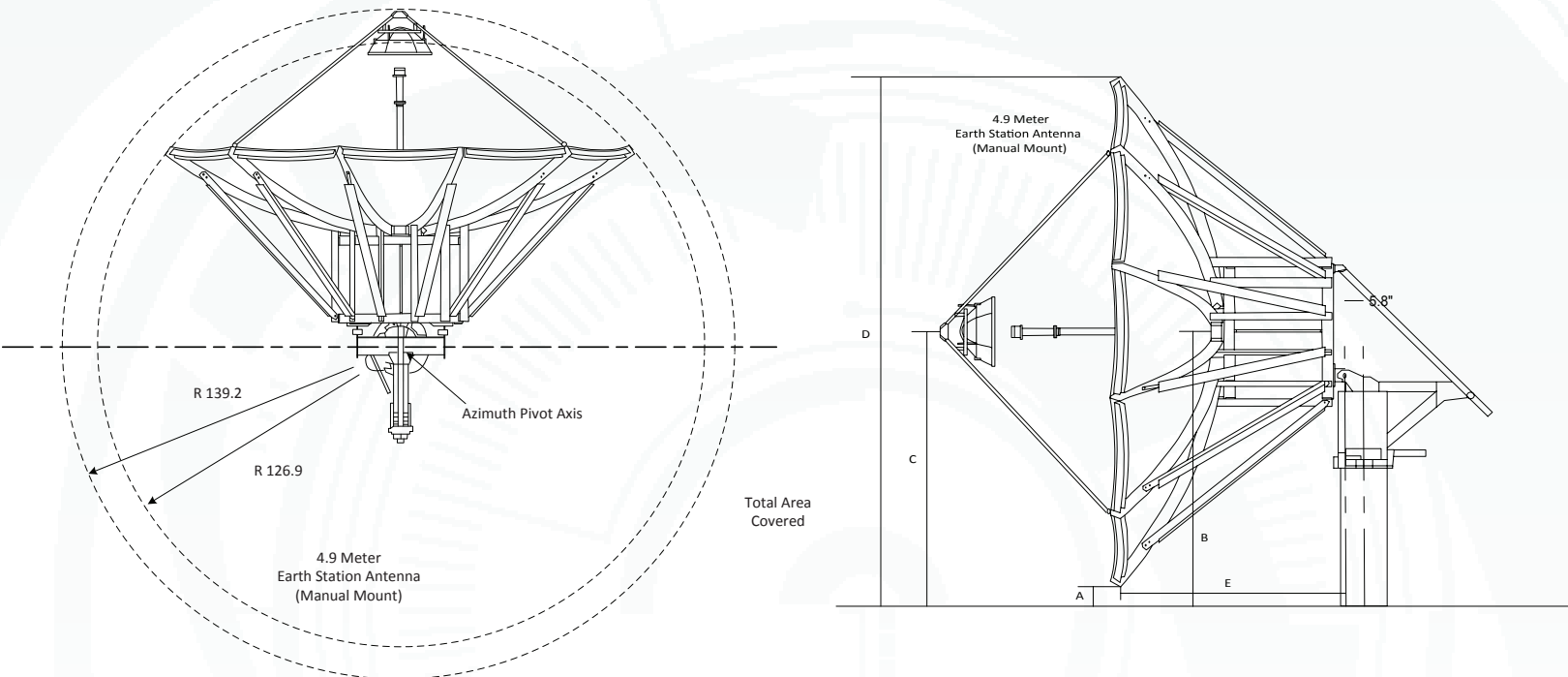

24/9 Powells Road, Brookvale,
 New South Wales 2100, Australia

+61 (02) 9939 4377

info@avcomm.com.au

4.9 Meter ESA

Typical Foundation Design

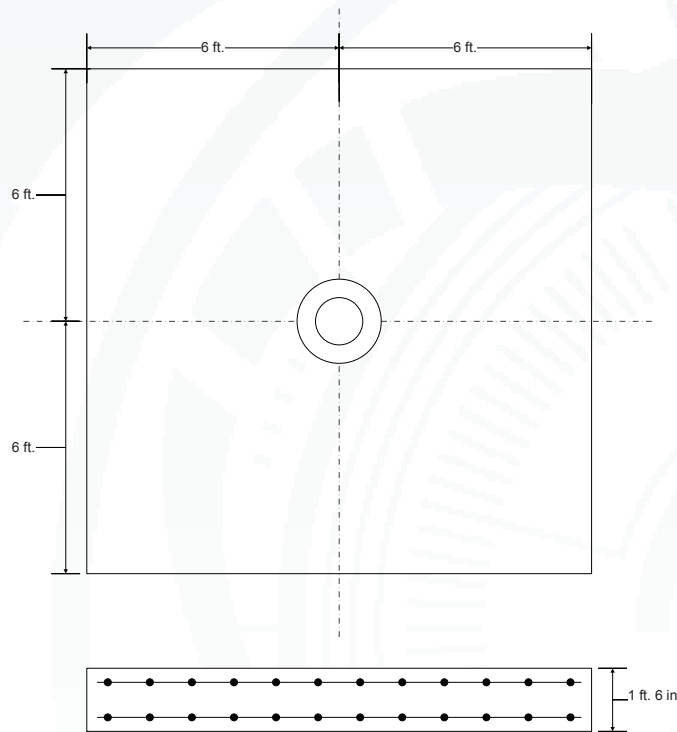

Typical Foundation Information

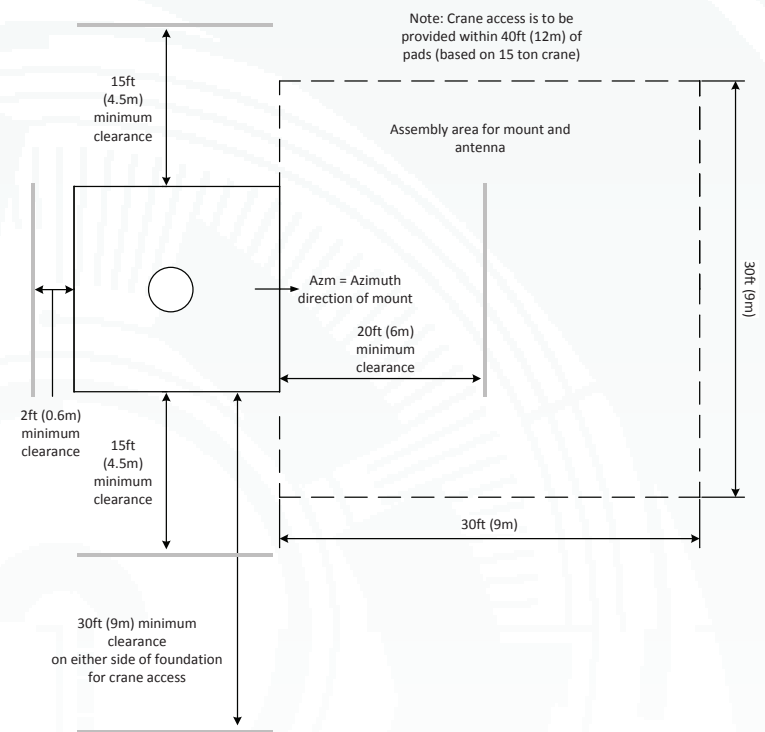

Foundation information are provided in bulletin 237636, please contact CPI Antenna Systems Division.

| | |
|---|---|
| Soil Bearing Capacity, | 2000 lb/ft ² (9770 kg/m ²) |
| Reinforcing Steel, | 821 lbs (372 kg) |
| Concrete Compressive Strength, | 3000 psi (211 kg/cm ²) |
| Foundation Size: | (for specific standard soil and typical design) |
| Length | 12 ft (3.66 m) |
| Width | 12 ft (3.66 m) |
| Depth | 1.5 ft (0.45 m) |
| Concrete Volume | 8 yd ³ (6.1 m ³) |
| NOTE: Other typical foundation designs are available. Soil borings and foundation analysis should be performed by a qualified civil engineer. | |

24/9 Powells Road, Brookvale,
 New South Wales 2100, Australia

+61 (02) 9939 4377

info@avcomm.com.au



4.9 Meter ESA

Antenna Configurations

Earth Station Antennas

| | |
|---|-----------|
| Manual Pedestal Mount. | ES49-1 |
| Motorizable Mount without Az/EI Jackscrews. | ES49MP-1 |
| Motorizable Mount with Az/EI Jackscrews. | ES49MPJ-1 |

Ka Band Earth Station Antennas

| | |
|---|-------------|
| Manual Pedestal Mount. | ES49KA-1 |
| Motorizable Mount without Az/EI Jackscrews. | ES49KAMP-1 |
| Motorizable Mount with Az/EI Jackscrews. | ES49KAMPJ-1 |

Low PIM Earth Station Antennas

| | |
|---|--------------|
| Manual Pedestal Mount. | ES49-LP-1 |
| Motorizable Mount without Az/EI Jackscrews. | ES49MP-LP-1 |
| Motorizable Mount with Az/EI Jackscrews. | ES49MPJ-LP-1 |

Ka Band Low PIM Earth Station Antennas

| | |
|---|----------------|
| Manual Pedestal Mount. | ES49KA-LP-1 |
| Motorizable Mount without Az/EI Jackscrews. | ES49KAMP-LP-1 |
| Motorizable Mount with Az/EI Jackscrews. | ES49KAMPJ-LP-1 |

Antenna controller and motorization are detailed in specific bulletins, please contact CPI Antenna Systems Division.

24/9 Powells Road, Brookvale,
New South Wales 2100, Australia

+61 (02) 9939 4377

info@avcomm.com.au



4.9 Meter ESA

Motor Drive Speed Summary

| | Variable | |
|--------------|----------|--------|
| Azimuth | 0.05°/s | 0.5°/s |
| Elevation | 0.05°/s | 0.5°/s |
| Polarization | 1°/s | |

Motorization

One motorization system is available for this antenna: the NGC tracking system that can support Steptrack, Smartrack and Ephemeris orbital tracking.

The NGC-IDU controller can also operate the Sub-Reflector tracking system SRT-2-49, 2 axis Control Sub-Reflector Carriage, required for Ka application.

Motor Kit

| | |
|---|-----------|
| Azimuth/Elevation Motor Kit | NGC-MK5 |
| Azimuth/Elevation Motor Kit , High Accuracy | NGC-MK5KA |

SRT Kit

| | |
|---------------------------------------|----------|
| 2 axis Control Sub-Reflector Carriage | SRT-2-49 |
|---------------------------------------|----------|

Polarization Drive Kit (DC Step Motors)

| | |
|-------------------------------------|---------------|
| Standard Temperature (> -20°C) | NGC-PK9DRA |
| Low Temperature operation (< -20°C) | NGC-PK9DRA-LO |

Outdoor Unit Controller (Tracking)

| | |
|---|------------------|
| Power 200 - 230 VAC, 3 Phase 50/60 Hz | NGC-ODU-208-3 |
| Power 380 - 460 VAC, 3 Phase 50/60 Hz | NGC-ODU-380-3 |
| Power 200 - 230 VAC, 3 Phase 50/60 Hz , High Accuracy | NGC-ODU-208-3-HA |
| Power 380 - 460 VAC, 3 Phase 50/60 Hz , High Accuracy | NGC-ODU-380-3-HA |
| NGC OUTDOOR INTERFACE FOR SRT | NGC-ODU-SRT |

Antenna controller, motorization and options are detailed in specific bulletins, please contact CPI Antenna Systems Division.

Motorization and NGC Options

| Indoor | |
|------------|---|
| NGC-IDU | NGC Rack Mounted Antenna Controller W/LCD Touch Panel |
| NGC-001 | NGC-IDU Analog Telephone Modem |
| NGC-002 | NGC-IDU Spectrum Analyzer Card, Analog |
| NGC-003 | NGC-IDU DVB Receiver Card |
| NGC-004-02 | NGC IDU, L-Band Internal Beacon Receiver |
| NGC-006 | NGC-IDU Emergency Stop Button |
| NGC-007 | NGC-IDU 10 Mhz Reference Source |
| NGC-008 | NGC-IDU Redundant Power Supply |
| NGC-009 | NGC-IDU Rack Slides |
| NGC-101 | NGC-IDU Step Tracking Software |
| NGC-102 | NGC-IDU Smartrack Software |
| NGC-103 | NGC-IDU Predictive Track Software |
| NGC-104 | NGC-IDU Full Tracking Capability Software |
| NGC-106 | NGC-IDU Remote Access Software Package |
| NGC-107 | NGC-IDU Spectrum Analyzer Enhanced User Interface |
| NGC-108 | Receive Pattern Test Tool |
| NGC-109 | Redundancy Control Software |
| NGC-111 | Sand/Dust Deviator Feature |
| NGC-119 | NGC High Availability System Redundancy Software |
| Outdoor | |
| NGC-201 | NGC ODU Low Temperature Kit (-40 C) |
| NGC-202 | NGC ODU High Temperature Kit (+60 C) |
| NGC-205 | NGC ODU AC Polarization Drive Interface |
| NGC-206 | NGC Exterior Emergency Stop Button |
| NGC-207 | Pre Movement Alert Warning Light And Annunciator |
| NGC-211 | Dual Path NGC Redundancy |
| NGC-AESC | Environmental System Controller |

Antenna controller, motorization and options are detailed in specific bulletins, please contact CPI Antenna Systems Division.

24/9 Powells Road, Brookvale,
New South Wales 2100, Australia

+61 (02) 9939 4377

info@avcomm.com.au



4.9 Meter ESA

Feed Matrix

| C- BAND FEED SYSTEMS | PORT | Co-Pol | CP | LP | RX 3.625 - 4.2 GHz | RX 3.4 - 4.2 GHz | RX 4.5 - 4.8 GHz | TX 5.850 - 6.425 GHz | TX 5.850 -6.725 GHz | TX 5.725 - 6.725 GHz | TX 6.725 - 7.025 GHz |
|----------------------|------|--------|----|----|--------------------|------------------|------------------|----------------------|---------------------|----------------------|----------------------|
| 2CLPNC-49 | 2 | X | | | X | | | X | | | |
| 2CPNC-49-109 | 2 | | X | | X | | | X | | | |
| 2CPNCR-49-109 | 2 | | X | | X | | | | | | |
| 2CPWCR-49-120 | 2 | | X | | | X | | | | | |
| 2LPNC-49 | 2 | | | X | X | | | X | | | |
| 2LPNCR-49 | 2 | | | X | X | | | | | | |
| 2LPUC-49 | 2 | | | X | | | X | | | | X |
| 2LPWC-49 | 2 | | | X | | X | | | | X | |
| 2LPWCR-49 | 2 | | | X | | X | | | | | |
| 4CPNC-49-206 | 4 | | X | | X | | | X | | | |
| 4LPNC-49 | 4 | | | X | X | | | X | | | |
| 4LPWWC-49 | 4 | | | X | | X | | | | X | |

| X- BAND FEED SYSTEMS | PORT | CP | RX 7.25 - 7.75 GHz | TX 7.9 - 8.4 GHz |
|----------------------|------|----|--------------------|------------------|
| 2CPX-49 | 2 | X | X | X |
| 2CPXF-49-C5 | 2 | X | X | X |

| Low PIM X- BAND FEED SYSTEMS | PORT | CP | RX 7.25 - 7.75 GHz | TX 7.9 - 8.4 GHz |
|------------------------------|------|----|--------------------|------------------|
| 2CPMX-49 | 2 | X | X | X |

24/9 Powells Road, Brookvale,
New South Wales 2100, Australia

+61 (02) 9939 4377

info@avcomm.com.au

4.9 Meter ESA

Feed Matrix (cont)

| Ku- BAND FEED SYSTEMS | PORT | LP | RX 10.95 - 12.75 GHz | RX 10.7 - 12.75 GHz | RX 10.7 - 11.7 GHz | TX 12.75- 13.25 GHz | TX 13.0 - 14.5 GHz | TX 13.75- 14.5 GHz | TX 13.75- 14.8 GHz |
|-----------------------|------|----|----------------------|---------------------|--------------------|---------------------|--------------------|--------------------|--------------------|
| 2LPKU-49 | 2 | X | | X | | | | | X |
| 2LPKUR-49-W | 2 | X | X | | | | | | |
| 4LPKU-49-1 | 4 | X | | X | | | | | X |
| 4LPKU-49-2 | 4 | X | | | X | X | | | X |
| 4LPKU-49-4 | 4 | X | | X | | | X | | |

| K- BAND FEED SYSTEMS | PORT | LP | RX 10.7 - 12.75 GHz | TX 17.3 - 18.4 GHz |
|----------------------|------|----|---------------------|--------------------|
| 2LPKK-49 | 2 | X | X | X |
| 4LPKK-49 | 4 | X | X | X |

| Ka- BAND FEED SYSTEMS | PORT | LP | CP | RX 17.7- 21.20 GHz | RX 20.2 - 21.2 GHz | TX 27.50 - 31.00 GHz | TX 30.0 - 31.0 GHz |
|-----------------------|------|----|----|--------------------|--------------------|----------------------|--------------------|
| 4CPMKA-49-206 | 2 | | X | | X | | X |
| 4CPWWKA-49 | 4 | | X | X | | X | |
| 4LPWWKA-49 | 4 | X | | X | | X | |

24/9 Powells Road, Brookvale,
 New South Wales 2100, Australia

+61 (02) 9939 4377

info@avcomm.com.au



4.9 Meter ESA

Antenna Options and Spares

Anchor Bolt and Template Kits Option

| | |
|--------|-------------------------------|
| 302689 | Anchor Bolt and Template Kits |
|--------|-------------------------------|

Azimuth and Elevation Cross Axis Waveguide Options

| | |
|--------------|---|
| XAPC-49 | C-Band Cross Axis and Polarization Axis Waveguide Kit. |
| XAPC-49-UPG | C-Band Cross Axis and Polarization Axis Waveguide Kit Upgrade. Upgrades XAPC-49 for use with 4-Port C-Band Feeds. Provides Additional Waveguide Run. |
| XAPKA-49 | Ka-Band Cross Axis and Polarization Axis Waveguide Kit.. |
| XAPKA-49-UPG | Ka-Band Cross Axis and Polarization Axis Waveguide Kit Upgrade. Upgrades XAPKA-49 for use with 4-port Ka-Band Feeds. Provides Additional Waveguide Run. |
| XAPKK-49 | K-Band cross Axis and Polarization Axis Waveguide Kit. |
| XAPKK-49-UPG | K-Band Cross Axis and Polarization Axis Waveguide Kit Upgrade. Upgrades XAPKK-49 for use with 4-port K-Band Feeds. |
| XAPKU-49 | Ku-Band Cross Axis and Polarization Axis Waveguide Kit. Single run for 2-Port Ku-Band Feeds. |
| XAPKU-49-UPG | Ku-Band Cross Axis and Polarization Axis Waveguide Kit Upgrade. Upgrades XAPKU-49 for use with 4-Port Ku-Band Feeds. Provides Additional Waveguide Run. |

Heating Options

| | |
|----------------|--|
| FH49C | C-Band Feed Heater Kit |
| FH49KA | Ka-Band Feed Heater |
| FH49KU-K | Ku and K-Band Feed Heater |
| WEC49R-208-100 | Electric Hot Air De-Ice System, 208 VAC, 3 Phase (not for Ka band) |
| WEC49R-380-100 | Electric Hot Air De-Ice System, 380 VAC, 3 Phase (not for Ka band) |

Hub Equipment Options

| | |
|------------------|----------------------------------|
| EMRGYLT-115 | Emergency Hub Light Kit, 115 VAC |
| EMRGYLT-230 | Emergency Hub Light Kit, 230 VAC |
| FV65-115 | Fan and Vent Kit, 115 VAC |
| FV65-220 | Fan and Vent Kit, 230 VAC |
| HUBHTR-230 | Antenna Hub Heater, 230 VAC |
| HUBLCNTR-115/240 | Hub Power Center, 115/240 VAC |
| HUBLCNTR-230 | Hub Power Center, 230 VAC |
| HUBLT-115 | Hub Light Kit, 115 VAC |
| HUBLT-230 | Hub Light Kit, 230 VAC |

Safety Options

| | |
|-------------|------------------------------------|
| ANTGND-5 | Foundation Installed Grounding Kit |
| LRK9 | Lightning Rod Kit |
| OBWRNLT-UNV | Obstruction Warning Light Kit |

Other Options

| | |
|------------|---|
| 221196 | Azimuth or Elevation Handwheel Kit (2 required) |
| 209906 | Lubrication and Maintenance Kit |
| BRNG-49-KU | Guard, Feed Window Ku-band |
| FTST | Feed System Testing |
| TK-MAN-SML | Tool Kit, Small Manual Antennas |
| TK-MOT-SML | Tool Kit, Small Motorized Antennas |

Environment Systems Options

| | |
|-------------|--|
| PDKA-49-208 | Precipitation Deviator Ka-band, 208 VAC, 3 Phase |
| PDKA-49-380 | Precipitation Deviator Ka-band, 380 VAC, 3 Phase |
| PDKU-49-208 | Precipitation Deviator Ku-K-band, 208 VAC, 3 Phase |
| PDKU-49-380 | Precipitation Deviator Ku-K-band, 380 VAC, 3 Phase |

24/9 Powells Road, Brookvale,
New South Wales 2100, Australia

+61 (02) 9939 4377

info@avcomm.com.au