

# 4.5 Meter Pedestal Mount ESA

Like all CPI Antenna Systems Division earth station antennas, the 4.5 Meter Earth Station Antenna provides high gain and exceptional pattern characteristics.

This antenna system is designed to address the stringent requirements of both the television broadcast industry and telecommunications network operators who demand unsurpassed flexibility and electrical performance in high-quality, cost-effective, and reliable packages.

The electrical performance and exceptional versatility provides the ability to configure the antenna in C-, X- and Ku-bands with the proper selection of feed and combiner systems. That versatility is provided at the time of initial purchase, as well as in the future, as your satellite communication requirements evolve.

This antenna system is used worldwide in broadcast applications and high density data, voice and communications networks. The CPI Antenna Systems Division 4.5 meter earth station antenna features a computer-optimized prime focus optics system and close-tolerance manufacturing techniques.

This combination provides extremely accurate surface contour resulting in exceptionally high gain and closely controlled pattern characteristics. CPI Antenna Systems Division earth station antennas provide maximum durability with minimal maintenance.



## Features

- Self-aligning main reflector requires no field alignment
- Prime focus feed system optics and fully-shaped parabolic main reflector provide excellent pattern characteristics
- 3 year warranty on all structural components
- C, X, Ku Band Capabilities

24/9 Powells Road, Brookvale,  
New South Wales 2100, Australia

+61 (02) 9939 4377

[info@avcomm.com.au](mailto:info@avcomm.com.au)



# 4.5 Meter Pedestal Mount ESA

## Design Standards

Reflector	Aluminum painted with highly diffusive white paint
Ground Mount	Hot-dipped galvanized steel, per ASTM-A123 for structural steel.
Hardware	Sizes ≤ 3/8 in (9.5mm), stainless steel, passivated per MIL-F-14072-E300 Sizes ≥ 3/8 in (9.5mm), hot-dipped galvanized stainless steel, passivated per ASTM-A123

## Environmental Performances

Operating Temperature	-40° to 52°C (-40° to 125°F)
Seismic (Earthquake)	1 G Vertical and Horizontal acceleration. Equivalent to a Richter Magnitude 8.3, and Grade 11 on the modified Mercalli Scale
Operational Winds	45 mph (72 km/h) Gusts to 65 mph (105 km/h)
Survival Winds	125 mph (200 km/h) in any position of operation
Rain	4 in (102 mm) per hour
Solar Radiation	360 BTU/hr/ft <sup>2</sup> (1135 Watts/m <sup>2</sup> )
Relative Humidity	100%
Shock and Vibration	As encountered by commercial Air, Rail and Truck shipment.
Atmospheric Conditions	As encountered by Moderately Corrosive Coastal and Industrial Areas.

## Mechanical Performances

The 4.5m Antenna mechanical general specifications and performances are listed in below table. Additional information, dimensions and layout may be provided by CPI Antenna Systems Division on a case-by-case basis.

Optics Type	Prime Focus
Reflector Material	Precision-Formed Aluminum
Reflector Segments	6
Mount Type	EI over Az, Pedestal Mount
<b>Antenna Pointing Range, Coarse/(Continuous)</b>	
Elevation:	0-90° (90°)
Azimuth:	180° (120°)
Polarization	180° (180°)

## Shipping Information

<b>Packing Options</b>	
Standard Commercial Domestic Pack	Included
Ocean Export Pack - For non-containerized, packed for seal against salt water spray	OCEANSHIP-SML
Air Export Pack - For freighter aircraft shipments. Lower deck AirPack requires specialized bids	AIR-EXPORT-PACK-SML
Container Packaging	CNTPCK-SML
<b>Required Shipping Container</b>	
Standard 20 ft land/sea container	Quantity 1

Shipping container information is given for basic configuration and may vary depending on the selected options, please contact CPI Antenna Systems Division for specific container loading plan.

24/9 Powells Road, Brookvale,  
New South Wales 2100, Australia

+61 (02) 9939 4377

info@avcomm.com.au

# 4.5 Meter Pedestal Mount ESA

## Dimensional Drawings Non Motorizable Mount

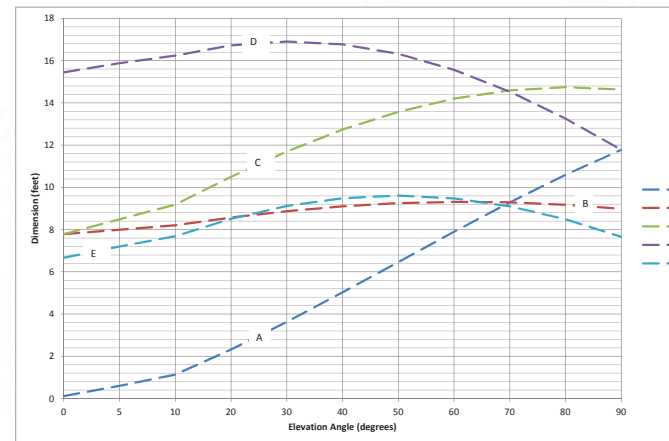
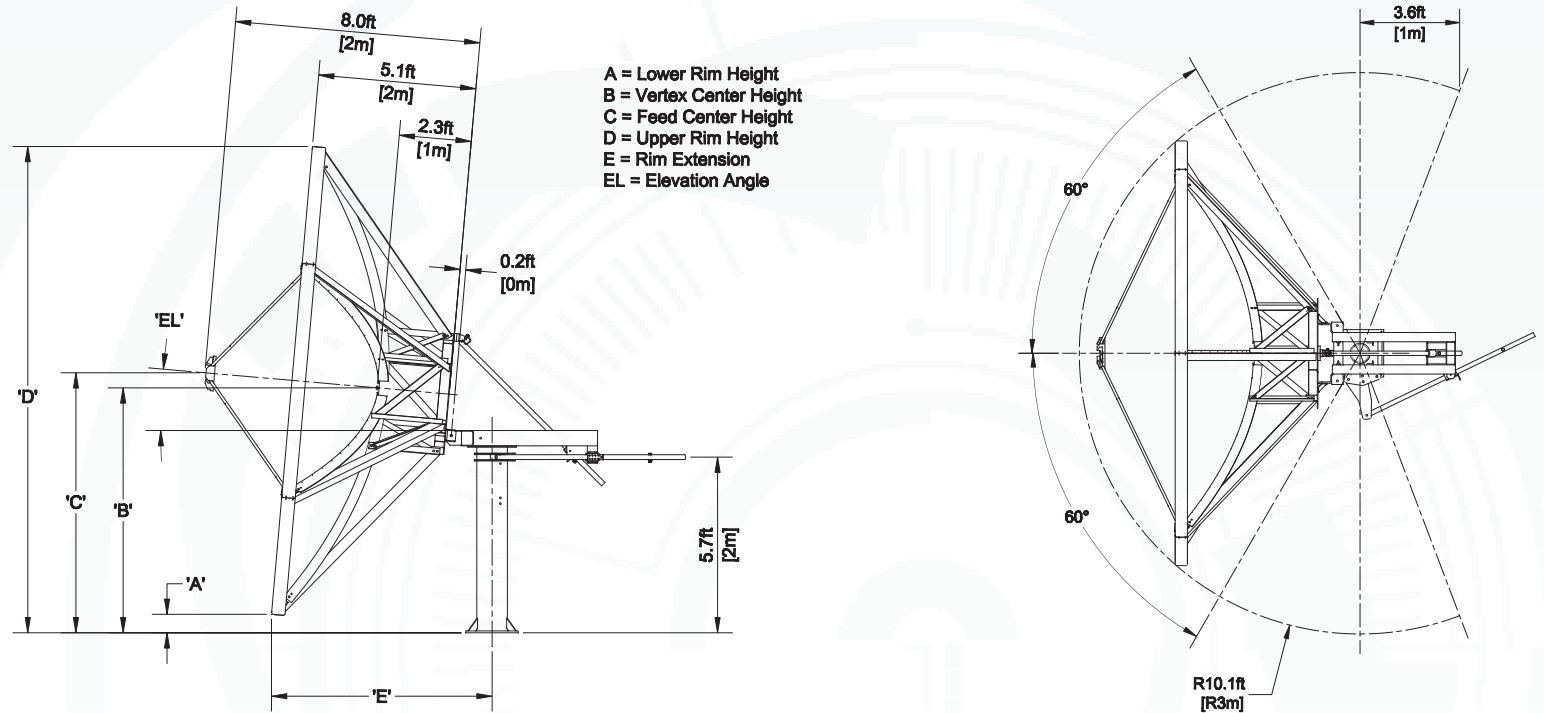

24/9 Powells Road, Brookvale,  
 New South Wales 2100, Australia

+61 (02) 9939 4377

info@avcomm.com.au

# 4.5 Meter Pedestal Mount ESA

## Dimensional Drawings Motorizable Mount

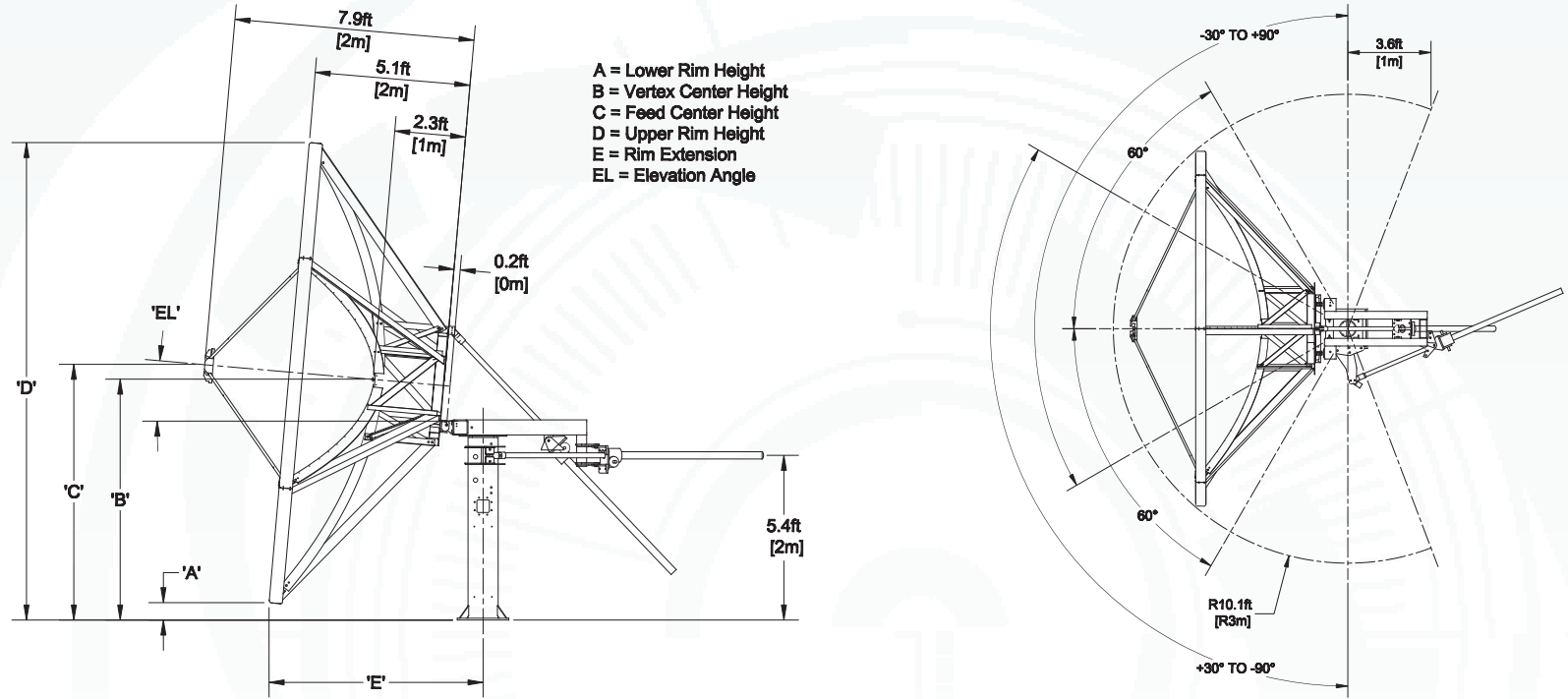

A = Lower Rim Height  
 B = Vertex Center Height  
 C = Feed Center Height  
 D = Upper Rim Height  
 E = Rim Extension  
 EL = Elevation Angle

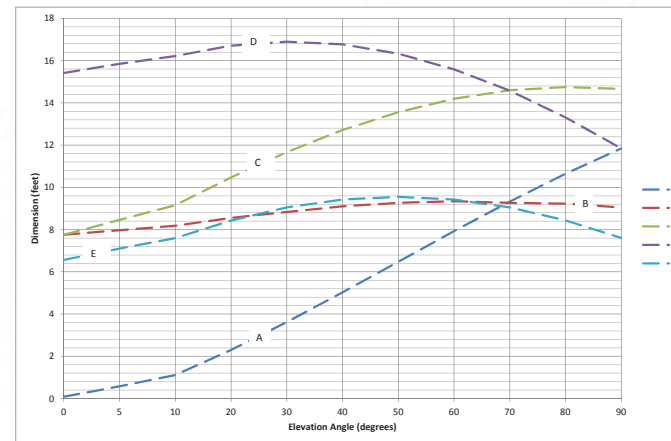

24/9 Powells Road, Brookvale,  
 New South Wales 2100, Australia

+61 (02) 9939 4377

info@avcomm.com.au

# 4.5 Meter Pedestal Mount ESA

## Foundation, Typical Slab

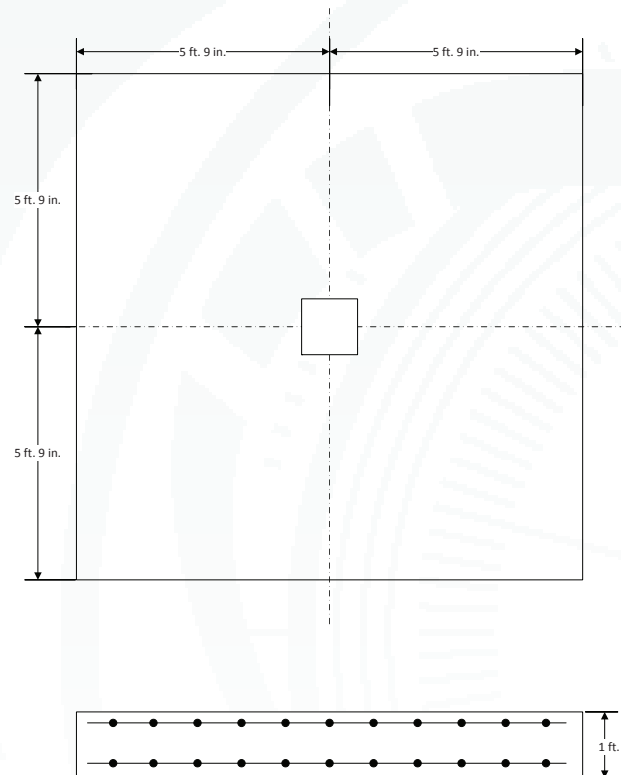

Foundation information are provided in bulletin 37846C, please contact CPI Antenna Systems Division.

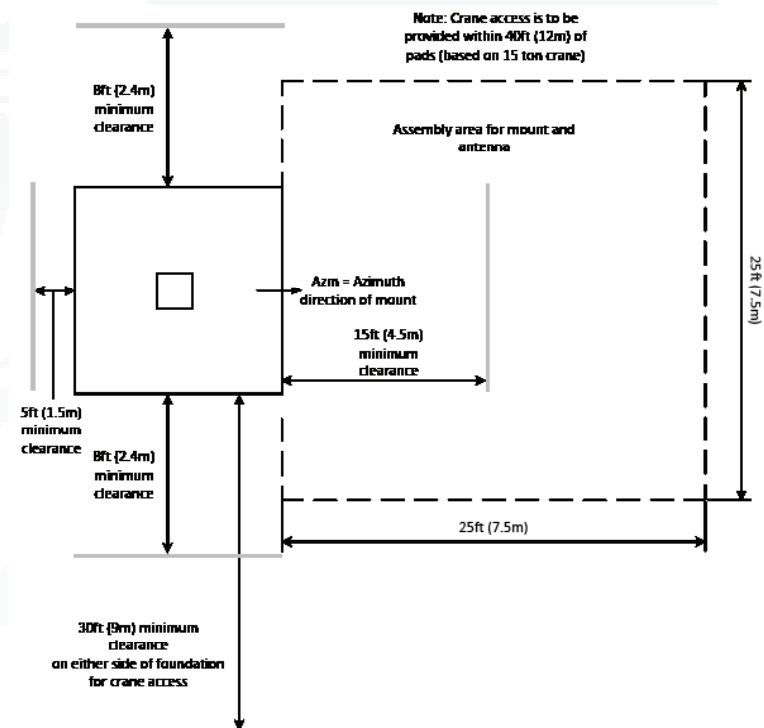

Soil Bearing Capacity,	2000 lb/ft <sup>2</sup> (9770 kg/m <sup>2</sup> )
Reinforcing Steel,	688 Lbs (312 Kilograms)
Concrete Compressive Strength,	3000 psi (211 kg/cm <sup>2</sup> )
Foundation Size:	(for specific standard soil and typical design)
Length	11 ft 6 in(3.5 m)
Width	11 ft 6 in(3.5 m)
Depth	1 ft 6 in(0.457 m)
Concrete Volume	7.35 yd <sup>3</sup> (5.62 m <sup>3</sup> )

NOTE: Other typical foundation designs are available. Soil borings and foundation analysis should be performed by a qualified civil engineer.

24/9 Powells Road, Brookvale,  
 New South Wales 2100, Australia

+61 (02) 9939 4377

info@avcomm.com.au



# 4.5 Meter Pedestal Mount ESA

## Motor Drive Speed Summary

	Variable	
Azimuth	0.5°/s	0.05°/s
Elevation	0.5°/s	0.05°/s
Polarization	1°/s	

## Motorization

One motorization system is available for this antenna: the NGC tracking system can support Steptrack, Smartrack and Ephemeris orbital tracking.

### Motor Kit

Azimuth/Elevation Motor Kit	NGC-MK4
-----------------------------	---------

### Polarization Drive Kit (DC Step Motors)

Standard Temperature (> -20°C)	NGC-PK5PF
--------------------------------	-----------

### Outdoor Unit Controller (Tracking)

Power 200 - 230 VAC, 3 Phase 50/60 Hz	NGC-ODU-208-3
Power 380 - 460 VAC, 3 Phase 50/60 Hz	NGC-ODU-380-3

Antenna controller, motorization and options are detailed in specific bulletins, please contact CPI Antenna Systems Division..

## Antenna Configurations

### C, X, Ku Band Earth Station Antennas

Manual Pedestal Mount with Az/EL struts.	ES45P-1
Motorizable Mount with Az/EL struts.	ES45MP-1
Motorizable Mount with Az/El Jackscrews.	ES45MPJ-1

## Motorization and NGC Options

Indoor	
NGC-IDU	NGC Rack Mounted Antenna Controller W/LCD Touch Panel
NGC-001	NGC-IDU Analog Telephone Modem
NGC-002	NGC-IDU Spectrum Analyzer Card, Analog
NGC-003	NGC-IDU DVB Receiver Card
NGC-004-02	NGC IDU, L-Band Internal Beacon Receiver
NGC-006	NGC-IDU Emergency Stop Button
NGC-007	NGC-IDU 10 Mhz Reference Source
NGC-008	NGC-IDU Redundant Power Supply
NGC-009	NGC-IDU Rack Slides
NGC-101	NGC-IDU Step Tracking Software
NGC-102	NGC-IDU Smartrack Software
NGC-103	NGC-IDU Predictive Track Software
NGC-104	NGC-IDU Full Tracking Capability Software
NGC-106	NGC-IDU Remote Access Software Package
NGC-107	NGC-IDU Spectrum Analyzer Enhanced User Interface
NGC-108	Receive Pattern Test Tool
NGC-109	Redundancy Control Software
NGC-119	NGC High Availability System Redundancy Software
Outdoor	
NGC-201	NGC ODU Low Temperature Kit (-40 C)
NGC-202	NGC ODU High Temperature Kit (+60 C)
NGC-205	NGC ODU AC Polarization Drive Interface
NGC-206	NGC Exterior Emergency Stop Button
NGC-207	Pre Movement Alert Warning Light And Annunciator
NGC-211	Dual Path NGC Redundancy
NGC-AESC	Environmental System Controller

24/9 Powells Road, Brookvale,  
New South Wales 2100, Australia

+61 (02) 9939 4377

info@avcomm.com.au



# 4.5 Meter Pedestal Mount ESA

## Feed Matrix

C- BAND FEED SYSTEMS	PORT	CP	LP	CO	RX 3.4 - 4.2 GHz	RX 3.625 - 4.2 GHz	RX 4.5 - 4.8 GHz	TX 5.850 - 6.425 GHz	TX 5.850 - 6.725 GHz	TX 6.725 - 7.025 GHz
2CLPC-45	2			X		X		X		
2CPC-45-109	2	X	X			X		X		
2CPCR-45-109	2	X				X				
2CPWCR-45-120	2	X			X					
2LPC-45	2		X			X		X		
2LPCR-45	2		X			X				
2LPWC-45	2		X		X				X	
2LPWCR-45	2		X		X					
2LPUC-45	2		X				X			X
4CPNC-45-206	4	X				X		X		
4LPCM-45	4		X			X		X		

X- BAND FEED SYSTEMS	PORT	CP	RX 7.25 - 7.75 GHz	TX 7.9 - 8.4 GHz
2CPX-45	2	X	X	X

Ku- BAND FEED SYSTEMS	PORT	LP	RX 10.95- 12.75 GHz	RX 10.7 - 13.25 GHz	TX 13.75- 14.8 GHz
2LPKR-45-W	2	X	X		
2LPKUNV-45	2	X		X	X

C/Ku- BAND FEED SYSTEMS	PORT	KU LP	C LP	C CP	RX 3.625 - 4.2 GHz	RX 10.95- 12.75 GHz
4CPCLKR-45-W	4	X		X	X	X
4LPCKR-45-W	4	X	X		X	X

24/9 Powells Road, Brookvale,  
New South Wales 2100, Australia

+61 (02) 9939 4377

info@avcomm.com.au



# 4.5 Meter Pedestal Mount ESA

## Antenna Options and Spares

Anchor Bolt and Template Kits Option	
203666	Anchor Bolt Kit for 4.5 Meter Earth Station
Azimuth and Elevation Cross Axis Waveguide Options	
1XAC-45	C-Band Cross Axis Waveguide Kit, 2-Port.
1XPC-45	C-Band Polarization Waveguide Kit, 2-Port.
1XPK-45	Ku-Band Polarization Waveguide Kit, 2-Port.
2XAC-45	C-Band Cross Axis Waveguide Kit, 4-Port.
2XPC-45	C-Band Polarization Waveguide Kit, 4-Port.
2XPK-45	Ku-Band Polarization Waveguide Kit, 4-Port.
Heating Options	
FR45A	Full-Reflector Heater Pads
WEC45R-208-100	Electric Hot Air De-Ice System, 208 VAC, 3 Phase
WEC45R-380-100	Electric Hot Air De-Ice System, 380 VAC, 3 Phase

Safety Options	
ANTGND-5	Foundation Installed Grounding Kit
LRK5	Lightning Rod Kit
OBWRNLT-UNV	Obstruction Warning Light Kit
Other Options	
207885	Hand Crank Adjustment Kit
209906	Lubrication and Maintenance Kit
221196	Elevation Handwheel Kit (2 required)
7585441	Kit, Feed Constraint, 4.5M
FTST	Feed System Testing
TK-MAN-SML	Tool Kit, Small Manual Antennas
TK-MOT-SML	Tool Kit, Small Motorized Antennas

24/9 Powells Road, Brookvale,  
New South Wales 2100, Australia

+61 (02) 9939 4377

info@avcomm.com.au