

# EQ-90 Group Delay/Amplitude Equalizers



## INTRODUCTION

EQ-90 Group Delay/Amplitude Equalizers are used in satellite transmit/receive terminals to compensate for non-linear delay distortions and amplitude slope generated by the satellite, filters, waveguide, or inter-facility links. Fully compliant with DOMSAT and INTELSAT/CCIR standards, these units interface readily with the uplink/downlink chain.

## FEATURES

- Single or dual channel models
- One Rack Unit (1 RU) size
- 70 or 140 MHz IF
- 6 or 10 group delay sections per channel
- Amplitude slope adjustment
- +15 dB gain
- Interfaces directly with V90, V901, and ARC
- Continuously variable group delay and amplitude slope
- Fully compliant with all DOMSAT and INTELSAT/CCIR standards

## DESCRIPTION

The EQ-90 equalizer is a 1RU assembly that can be configured for single or dual-channel operation at 70 or 140 MHz.

Each channel of a dual-channel unit is completely independent of the other, including power supplies and fault/status monitoring capability. The dual-channel unit is a compact, lower-cost alternative to installing two single-channel units.

The number of group delay sections required depends upon the IF bandwidth, channel capacity, and RF carrier frequency. Each channel can have 6 or 10 delay sections. For narrow bandwidth applications, 6 delay sections are generally sufficient, unless the RF carrier frequency is located near the useable transponder band edge.

## OPERATION

EQ-90 equalizers offer exceptional flexibility of delay/amplitude response shaping. The equalizer module permits virtually any delay shape within a considerable range of adjustments.

The delay equalizer module has 6 or 10 sections that may be switched in or out of the through-path, with continuously adjustable delay magnitude and frequency (parabolic or linear delay), as well as amplitude/slope correction. For example, two sections can double the delay magnitude. The frequency may be varied to provide flat, "double-humped," true parabolic delay and slope response. It can also be adjusted to provide delay ripple. An amplitude equalizer section provides continuous adjustment for cable amplitude/slope equalization.

### EQ90 - Configuration Selection Guide

	EQ90 -	CHAN ( )	IF ( )	SECTIONS ( )
		↕	↕	↕
<b>Channels:</b>	Single Dual	(S) (D)		
<b>IF:</b>	70 MHz 140 MHz		(7) (14)	
<b>Sections:</b>	6 Section 10 Section (70 MHz only)			(6) (10)
<b>Examples:</b>	EQ90-S76 is a single channel, 70 MHz, 6 section unit EQ90-D710 is a dual channel, 70 MHz, 10 section unit			

# EQ-90 Group Delay/Amplitude Equalizers

## Input/Output Characteristics

Frequency	70 ± 18 MHz 140 ± 36 MHz
Level	-15 dBm, maximum, single carrier -18 dBm, maximum, multi-carrier composite
Impedance	75 Ohms, unbalanced
Return Loss	20 dB, minimum
Connector	BNC, female (rear panel)
Gain	15 dB, nominal
1 dB compression	+8 dBm, minimum
3rd Order Intercept	+18 dBm, minimum
Group Delay	< 2 ns, all equalizer sections bypassed
Amplitude Adjustment	± 3 dB, minimum
Amplitude Response	Adjustable to ± 0.15 dB, maximum
Delay Adjustment (per section)	70 MHz, < 15 ns ± 18 MHz, to > 40 ns ± 18 MHz 140 MHz, < 10 ns ± 36 MHz, to >30 ns ± 36 MHz
IF Fail Trip Point	Approximately -20 dBm output power
Fault/Status Output Type	(1) Sum fail, fail-safe, form "C" relay contact, form "A" relay contact
Fault	IF output level monitor, internal power supply monitor
Connector	9-pin D male

## Primary Power Requirements

Voltage	Universal input, 90 to 265 VAC
Frequency	47 to 63 Hz
Power Consumption	15 Watts per channel, nominal

## Environmental

Temperature	
Operating	0 to 50°C (32 to 122° F)
Non-Operating	-30 to +75°C (-22 to 167° F)
Maximum Altitude	
Operating	10,000 feet (3,048 meters)
Non-operating	40,000 feet (12,192 meters)
Humidity	
Operating	0 to 95% (non-condensing)
Non-operating	0 to 95% (non-condensing)
Dimension	1.75 H x 17 W x 20 D inches (4.44 H x 48.26 W x 50.80 D cm)
Weight	15lb. (6.8 kg.)

## Delay Equalizer Board

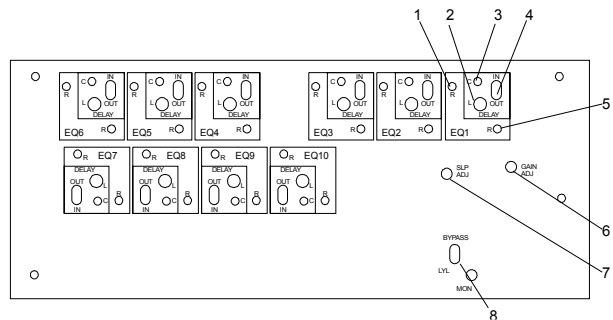

Item	Nomenclature	Function
1	R	Used to adjust the amplitude tilt.
2	L	Used to adjust the delay peak magnitude.
3	C	Used to adjust the delay peak center frequency.
4	IN/OUT	Used to insert or remove an equalizer delay section to the signal path.
5	R	Used to adjust the amplitude response.
6	Gain ADJ Potentiometer	Used to set the IF output signal gain (nominally 15 dB).
7	SLP ADJ Potentiometer	Used to provide ±3 dB amplitude slope equalization.
8	BYPASS/LVL MON Switch	Used to activate the IF output signal level monitoring function. The minimum signal level required to avoid an alarm condition is -20 dB. In the BYPASS position, the signal level is not monitored, however a power supply failure will result in an alarm condition.

