

# Block Up Converter 6700 and 6900 series

Codan's L-Band IF input 6700 series C-Band and 6900 series Ku-Band Block Up Converters (BUCs) offer a wide range of distinctive advantages and enhanced features for satellite communications systems. Available in a variety of models, the 6700 and 6900 series BUCs provide industry-leading technical performance.

## KEY FEATURES

### Configuration

The 6700 and 6900 series compact L-Band IF input Block Up Converters (BUCs) are available in C-Band and Ku-Band versions and a range of RF output powers.

### Durability

The 6700 and 6900 series are designed and tested to meet their performance specifications over an ambient temperature range of -40°C to +55°C and up to 100% relative humidity, ensuring long term survival in extreme conditions. Field experience for Codan BUCs shows that MTBFs of greater than 100,000 hours can be expected.

### RF performance

RF performance is superior, particularly: intermodulation performance, gain stability over temperature and flatness across the IF band. The 6700 and 6900 series also boast industry leading spurious and harmonics specifications. Guaranteed RF performance ensures expensive system link margins do not have to be used to cope with RF transceiver variations.

### CE compatible

While CE certified versions are available, all BUCs are designed to ensure that the customer can easily achieve CE certification at a system level for a transmission system in the EU.

All Codan BUCs are tested to the following standards:

#### EMI/EMC Directive

- EN 301 489 – 1 (as per Article 3.1b in the RTT&E Directive)
- EN 301 489 – 12 (as per Article 3.1b in the RTT&E Directive)

#### LV Directive

- EN60950 (as per Article 3.1a in the RTT&E Directive)
- CR 1999/519/EC and ICNIRP Guidelines

### Power

Codan BUCs all feature low power consumption and low temperature rise, ensuring internal components do not suffer undue stress. DC-powered BUCs are powered either via the transmit IF cable or optional external DC power connector.

AC-powered BUC modules are AC mains powered via an external connector.

### Internal protection

Internal protection against high temperature and short or open circuit RF output is standard. Input voltage detection ensures reliable shutdown and restart under brownout or blackout conditions.

### External protection

The BUCs are completely protected from the elements, are without external user controls, and are fully sealed and pressure tested to 34 kPa (5 psi). Particle and moisture penetration is rated to IP67. High quality paint is used to protect the modules from corrosion.



C-Band Low power Block Up Converter

## ADVANCED FEATURES

### Enhanced monitor and control

All operating functions can be controlled and monitored via the serial M&C facilities. The standard output power meter facility features high accuracy and the ability to measure both CW and burst mode signals. The 6700 and 6900 series is capable of operating with a PC without requiring proprietary software. The user has the choice of an FSK based M&C interface, which is

fed via the transmit IF cable for use with intelligent modems or separate RS232 or RS422/RS485 interfaces. Multiple M&C protocols are provided to enable integration into a number of network management systems.

## BUC PART NUMBER FORMAT

6FPP-X/Y-AA/BB-GG-ZZ

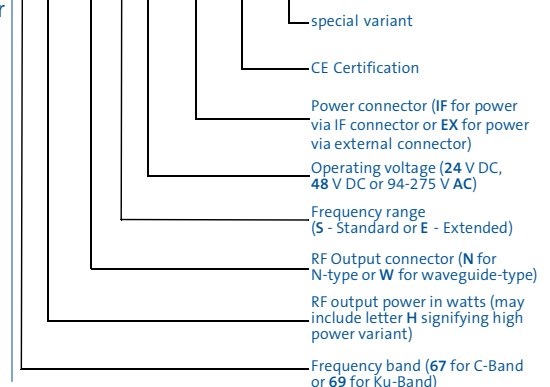

SPECIFICATIONS

	C-BAND 6700 SERIES						KU-BAND 6900 SERIES							
Power rating	5 W	10 W		20 W	25 W	40 W	60 W	4 W	8 W		16 W		25 W	
Platform	DC-powered	DC-powered		DC-powered	AC-powered	AC-powered	AC-powered	DC-powered	DC-powered		DC-powered	AC-powered		AC-powered
Frequency range	950 to 1525 MHz	950 to 1525 MHz	950 to 1750 MHz	950 to 1525 MHz	950 to 1750 MHz	950 to 1750 MHz	950 to 1525 MHz	950 to 1700 MHz	950 to 1450 MHz	950 to 1700 MHz	950 to 1450 MHz		950 to 1700 MHz	950 to 1450 MHz
Model numbers	6705-W/S-48/IF 6705-N/S-48/IF 6705-W/S-24/IF 6705-N/S-24/IF	6710-W/S-48/IF 6710-N/S-48/IF	6710-W/E-48/IF-CE 6710-N/E-48/IF-CE 6710-W/E-48/EX-CE 6710-N/E-48/EX-CE	6720-W/S-48/IF-CE 6720-N/S-48/IF-CE 6720-W/S-48/EX-CE 6720-N/S-48/EX-CE	6725-W/E-AC/EX-CE 6725-N/E-AC/EX-CE	6740-W/E-AC/EX-CE 6740-N/E-AC/EX-CE	6760-W/S-AC/EX-CE	6904-W/E-24/IF-CE 6904-W/E-48/IF-CE	6908-W/S-48/IF, 6908-W/E-48/IF-CE, 6908-W/E-48/EX-CE		6916-W/S-48/IF 6916-W/S-48/EX	6916-W/S-AC/EX	6916-W/E-AC/EX	6925-W/S-AC/EX-CE
Gain	68 dB nominal	71 dB nominal		74 dB nominal	74 dB nominal	77 dB nominal	79 dB nominal	67 dB nominal	70 dB nominal		73 dB nominal		74 dB nominal	
Gain flatness over any 40 MHz band	±1.50 dB max	±1.50 dB max	±0.75 dB max	±1.50 dB max	±0.75 dB max	±0.75 dB max	±0.75 dB max	±1.50 dB max	±1.50 dB max	±0.75 dB max	±1.50 dB max	±0.75 dB max		±0.75 dB max
Gain flatness over full band	±2.50 dB max	±2.50 dB max	±1.50 dB max	±2.50 dB max	±1.50 dB max	±1.50 dB max	±1.50 dB max	±2.50 dB max	±2.50 dB max	±1.50 dB max	±2.50 dB max	±1.50 dB max		±1.50 dB max
Gain stability over any 50°C temperature range	±1.50 dB max	±1.50 dB max		±1.50 dB max	±1.50 dB max	±1.50 dB max	±1.50 dB max	±1.50 dB max	±1.50 dB max		±1.50 dB max	±1.50 dB max		±1.50 dB max
Gain stability over entire temperature range when frequency set	±2.0 dB max	±2.0 dB max		±2.0 dB max	±2.0 dB max	±2.0 dB max	±2.0 dB max	±2.0 dB max	±2.0 dB max		±2.0 dB max		±2.0 dB max	
Gain stability over entire temperature range when frequency not set	±3.0 dB max	±4.0 dB max	±3.0 dB max	±3.0 dB max	±3.0 dB max	±3.0 dB max	±3.0 dB max	±4.0 dB max	±4.0 dB max	±3.0 dB max	±3.0 dB max		±3.0 dB max	
RF output frequency range	5850 to 6425 MHz	5850 to 6425 MHz	5850 to 6725 MHz	5850 to 6425 MHz	5850 to 6725 MHz	5850 to 6725 MHz	5850 to 6425 MHz	13750 to 14500 MHz	14000 to 14500 MHz	13750 to 14500 MHz	14000 to 14500 MHz		13750 to 14500 MHz	14000 to 14500 MHz
RF output connector	N-type or CPR137G with 5 mm through holes	N-type or CPR137G with 5 mm through holes		N-type or CPR137G with 5 mm through holes	N-type or CPR137G with 5 mm through holes	N-type or CPR137G with 5 mm through holes	N-type or CPR137G with 5 mm through holes	WR75, PBR120 flange with 4.2 mm through holes	WR75, PBR120 flange with 4.2 mm through holes		WR75, PBR120 flange with 4.2 mm through holes		WR75, PBR120 flange with 4.2 mm through holes	
RF output VSWR	2.0:1 max	2.0:1 max	1.8:1 max	1.8:1 max	1.5:1 max	1.5:1 max	1.5:1 max	2.0:1 max	2.0:1 max	1.8:1 max	1.5:1 max		1.5:1 max	
RF output power at 1 dB GCP	+37.0 dBm min	+39.0 dBm min	+40.0 dBm min	+43.0 dBm min	+43.0 dBm min	+46.0 dBm min	+47.8 dBm min	+36.0 dBm min	+38.0 dBm min	+39.0 dBm min	+42.0 dBm min	+42.0 dBm min	+42.0 dBm min	+43.4 dBm min
RF output IMD ratio with 2 carriers each at 3 dB OPBO	-26 dBc min	-26 dBc min		-26 dBc min	-25 dBc min	-25 dBc min	-25 dBc min	-25 dBc min	-24 dBc min	-25 dBc min	-25 dBc min		-25 dBc min	
Spurious output @ 3 dB OPBO	-50 dBc max	-50 dBc max		-50 dBc max	-50 dBc max	-50 dBc max	-50 dBc max	-50 dBc max	-50 dBc max		-50 dBc max		-50 dBc max	
Output power meter range	15 dB	15 dB		15 dB	10 dB	15 dB	15 dB	15 dB	15 dB		15 dB	10 dB		15 dB
LO frequency	7300 MHz & 7375 MHz	7300 MHz & 7375 MHz	7300 MHz, 7375 MHz, 7600 MHz & 7675 MHz	7300 MHz & 7375 MHz	7300 MHz, 7375 MHz, 7600 MHz & 7675 MHz	7300 MHz, 7375 MHz, 7600 MHz & 7675 MHz	7300 MHz & 7375 MHz	15450 MHz	15450 MHz		15450 MHz		15450 MHz	
Power supply voltage @ 24 V	+19 V to +35 V DC via transmit IF input							+19 V to +35 V DC via transmit IF input						
Power supply voltage @ 48 V	+42 V to +60 V DC via transmit IF input	+42 V to +60 V DC via transmit IF input	+42 V to +60 V DC via transmit IF input or via external DC connector	+42 V to +60 V DC via transmit IF input or via external DC connector				+42 V to +60 V DC via transmit IF input	+42 V to +60 V DC via transmit IF input	+42 V to +60 V DC via transmit IF input or via external DC connector	+42 V to +60 V DC via transmit IF input or via external DC connector			
Power supply voltage @ AC					94 to 275 V AC via Amphenol T 3110 000	94 to 275 V AC via Amphenol T 3110 000	94 to 275 V AC via Amphenol T 3110 000					94 to 275 V AC via Amphenol T 3110 000	94 to 275 V AC via Amphenol T 3110 000	
Power supply consumption	60 W max	130 W max		150 W max	240 W max	375 W max	580 W max	80 W max	130 W max		150 W max	300 W max		375 W max
AC-powered BUC fault monitor connector					Transmit IF input	Transmit IF input	Transmit IF input					Transmit IF input		Transmit IF input
AC-powered BUC fault monitor polarity					+ve on centre conductor	+ve on centre conductor	+ve on centre conductor					+ve on centre conductor		+ve on centre conductor
AC-powered BUC fault monitor no fault state					>23 mA at 48 V DC	>23 mA at 48 V DC	>23 mA at 48 V DC					>23 mA at 48 V DC		>23 mA at 48 V DC
AC-powered BUC fault monitor fault state					<20 mA at 48 V DC	<20 mA at 48 V DC	<20 mA at 48 V DC					<20 mA at 48 V DC		<20 mA at 48 V DC
Volume (for waveguide output BUCs)	335 mm L x 182 mm W x 104 mm H	335 mm L x 182 mm W x 137 mm H		335 mm L x 182 mm W x 137 mm H	497 mm L x 182 mm W x 204 mm H	497 mm L x 182 mm W x 204 mm H	497 mm L x 182 mm W x 216 mm H	360 mm L x 182 mm W x 104 mm H	360 mm L x 182 mm W x 137 mm H		360 mm L x 182 mm W x 137 mm H	522 mm L x 182 mm W x 204 mm H		522 mm L x 182 mm W x 204 mm H
Weight	5.6 kg nominal	6.5 kg nominal		6.5 kg nominal	11.8 kg nominal	11.8 kg nominal	15 kg nominal	6.0 kg nominal	6.5 kg nominal		6.5 kg nominal	11.8 kg nominal		11.8 kg nominal

## COMMON SPECIFICATIONS 6700 AND 6900 SERIES

IF input connector	N-type
IF input impedance	50 Ω
IF input VSWR	1.5:1 max
Transmit attenuator steps	0 dB to 12 dB in 4 dB steps
Output power meter absolute accuracy when compensation frequency set	±1.0 dB max
Output power meter absolute accuracy when compensation frequency not set	±2.0 dB max
Output power meter relative accuracy when compensation frequency set	±1.0 dB max
Output power meter relative accuracy when compensation frequency not set	±0.5 dB max
Power meter modes	CW and burst with adjustable threshold
Reference frequency	10 MHz
Reference frequency input	Multiplexed on transmit IF input
Reference frequency level	-10 to +5 dBm
Reference frequency connector	Via transmit IF input
Frequency conversion	Spectrum inverting
Phase noise (SSB) of RF output signal (assuming maximum phase noise (SSB) of reference frequency * is met):	
100 Hz	-63 dBc/Hz
1 kHz	-73 dBc/Hz
10 kHz	-73 dBc/Hz
100 kHz	-83 dBc/Hz
* Maximum phase noise (SSB) of reference frequency:	
100 Hz	-135 dBc/Hz
1 kHz	-145 dBc/Hz
10 kHz	-155 dBc/Hz
100 kHz	-155 dBc/Hz
Monitor & Control (FSK) data format	User selectable
Monitor & Control (FSK) data transmitter frequency	650 kHz ±1%
Monitor & Control (FSK) data transmitter deviation	±60 kHz ±1%
Monitor & Control (FSK) data transmitter sense	+60 kHz=mark; -60 kHz=space
Monitor & Control (FSK) output level	-3 dB nominal
Monitor & Control (FSK) start tone time	10 ms minimum
Monitor & Control (FSK) data receiver nominal frequency	650 kHz
Monitor & Control (FSK) data receiver locking range	±30 kHz
Monitor & Control (FSK) data receiver input sensitivity	-15 dBm minimum
Monitor & Control (Digital) data format RS232	9600 bps, 8 bits, no parity, 1 stop bit, ASCII protocol
Monitor & Control (Digital) data format RS485	User selectable
Monitor & Control (Digital) connector	MIL-C-26482 12-14S socket
Operating temperature range	-40 to +55°C
Relative humidity	100%
Weatherproofing	Sealed to 34 kPa

### CODAN QUALITY AND SERVICE

All BUCs are built and tested in Codan's ISO9001 quality certified manufacturing facility, and undergo burn in and performance monitoring over the temperature range specified. Codan's fully trained staff and agents provide in-factory and in-country training services and complete installation and on-site assistance. This service is backed by a 24-hour customer service line

and a warranty of three years on manufacturing, design or component defects.



*C-Band Medium power Block Up Converter*

### CONFIGURATION OPTIONS

Refer to the Specifications on this data sheet for allowed combinations of configuration options.

For accessories and options, please refer to the Block Up Converter Accessories data sheet (Codan part number 12-20185-EN).

Equipment descriptions and specifications are subject to change without notice or obligation.

Head Office	Asia Pacific	EMEA	Americas	12-20184 Issue 3: 2/07
Codan Limited ABN 77 007 590 605 81 Graves Street Newton SA 5074 AUSTRALIA Telephone +61 8 8305 0311 Facsimile +61 8 8305 0411 <a href="http://www.codan.com.au">www.codan.com.au</a>	Codan Limited 81 Graves Street Newton SA 5074 AUSTRALIA Telephone +61 8 8305 0311 Facsimile +61 8 8305 0411 <a href="mailto:asiasales@codan.com.au">asiasales@codan.com.au</a>	Codan (UK) Ltd Gostrey House Union Road Farnham Surrey GU9 7PT UNITED KINGDOM Telephone +44 1252 717 272 Facsimile +44 1252 717 373 <a href="mailto:uksales@codan.com.au">uksales@codan.com.au</a>	Codan US, Inc. 8430 Kao Circle Manassas VA 20110 USA Telephone +1 703 361 2721 Facsimile +1 703 361 3812 <a href="mailto:ussales@codan.com.au">ussales@codan.com.au</a>	



CODAN

