

# MBT-4000 Outdoor Multi-Band RF Transceiver

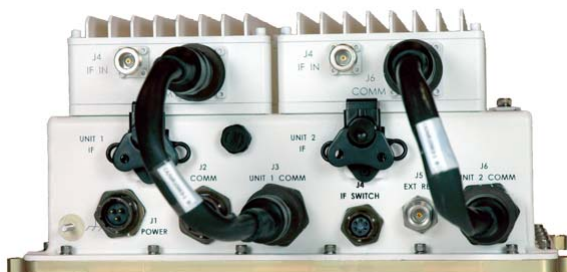

## INTRODUCTION

Comtech EF Data's MBT-4000 Multi-Band RF Transceiver is designed to perform C, X, or Ku RF to L-Band down conversion and L-Band to C, X, or Ku RF up conversion. Additionally, the MBT-4000 provides the following features:

- RF band switching in minimal time without requiring tools
- Minimal cost for a complete system including spares
- Easy expansion for providing a redundant system or other frequency bands
- Rugged construction for mobile and transportable applications
- Automatic band identification for the BUC, BDC, and antenna feed (if the feeds provide an identifying connector)
- Easy system status verification via LEDs located behind a removable cover
- Flexible configuration:
  - 2 Ups
  - 2 Downs
  - 1 Up and 1 Down

## SYSTEM OVERVIEW

The transceiver is constructed in a modular configuration. Common to the configuration for any frequency band of operation is a base module, which provides the M&C, Power Supply, and Reference function. Band-specific BUC and BDC modules can be quickly mounted to the base module with clip type fasteners. BUC and BDC modules for other bands and spares for all modules are stored in a transit case until needed.

## INSTALLATION AND OPERATION

The Common Module may be near or on the antenna. The band specific BUC and BDC is latched into place on top of the Common Module (M&C, Power Supply, and Reference). The cables to the antenna and the IDU complete the installation. To change the band of operation the cables to the BUC and BDC are removed and the clips released to allow the removal and replacement of the BUC/BDC with appropriate band-specific modules.

## BLOCK DOWN CONVERTER (BDC-4000)

The BDC-4000 translates a band specific input frequency block (C, X, or Ku), from the LNA, down to L-Band (950 to 2000 MHz).

### BDC-4000C, X, Ku, Ka

C-Band:	3400 to 4200 MHz
X-Band:	7250 to 7750 MHz
Ku-Band:	10.95 to 12.75 GHz
Ka-Band:	20.20 to 21.20 GHz (Future)

"No spectral inversion for X-, Ku-, and Ka-Band, selectable inversion for inverted C-Band Block Down Converter when part of DCS 4000 system."

- 10 dB gain adjustment

## BLOCK UP CONVERTER (BUC-4000)

The BUC-4000 translates the LBC-4000 L-Band output carrier to the desired output frequency (C, X, or Ku) with an output level capable of driving an HPA.

### BUC-4000C, X, Ku, Ka

C-Band:	5850 to 6650 MHz
X-Band:	7900 to 8400 MHz
Ku-Band:	13.75 to 14.50 GHz
Ka-Band:	30.00 to 31.00 GHz (Future)

- No spectral inversion
- 10 dB gain adjustment

## COMMON FEATURES

- Meets or exceeds MIL-STD-188-164A
- Low phase noise
- Auto band sensing capability

# MBT-4000 Outdoor Multi-Band RF Transceiver

## BUC-4000 Block Up Converter ODU

Input Frequency Range	950 to 2000 MHz
Output Frequency By Model:	
BUC-4000C	5860 – 6650 MHz
BUC-4000X	7900 – 8400 MHz
BUC-4000Ku	13.75 – 14.50 GHz
BUC-4000Ka	30.00 – 31.00 GHz
	27.50 – 28.50 GHz (optional)
	28.50 – 29.50 GHz (optional)
	29.50 – 30.10 GHz (optional)
Input/Output Impedance	50Ω
Input Return Loss	15 dB minimum
Output Return Loss	18 dB minimum
Input Connector	Type – N, female
Output Connector	N, Female (C-, X-, and Ku-Band)
Gain	15 dB nominal at minimum attenuation (18 dB for Ku-Band BUC)
User Attenuation Range	0 to 10 dB
Output Power, P1dB	+10 dBm minimum
Third Order Intercept	+20 dBm minimum
Carrier Spurious	-60 dBc
Non-Carrier Spurious	-60 dBm
External Reference	Input, either 5 or 10 MHz ±5 dBm optional

## UCS-4000 Combined Transfer Characteristics

Gain	40 dB nom at minimum attenuation
Gain Adjustment	50 dB, 0.25 dB steps (0.1 dB opt)
Gain Adjustment Accuracy	1.0 dB over 50 dB range
Gain Stability	±0.25 dB/day at constant temperature ±1.0 dB over temperature
Noise Figure	20 dB at minimum attenuation
AM/PM Conversion	0.1 deg/dB, max, to -5 dBm output
Group Delay:	
Linear	±0.05 ns/MHz
Parabolic	±0.01 ns/MHz <sup>2</sup>
Ripple	1 ns p-p
Third Order Intercept	+20 dBm
Amplitude Response	±0.50 dB over any 36 MHz (72 MHz) ±1.1 dB over full band

## Environmental and Physical

Operating Temperature:	
ODU: BUC-4000	-40° to +50°C (-40° to 122°F)
IDU: LBC-4000	-10° to +50°C (14° to 122 °F)
Operating Humidity	5 to 95 non-condensing
Operating Altitude	10,000 ft above sea level
Non-Operating Temperature:	
ODU: MBT-4000	-50° to +71°C (58° to 160°F)
Prime Power	90 to 260 VAC, 47 to 63 Hz
Size	Refer to the manual

## BDC-4000 Block Down Converter ODU

Input Frequency By Model:	
BDC-4000C	3400 to 4200 MHz
BDC-4000X	7250 to 7750 MHz
BDC-4000K	10.95 to 12.75 GHz
BDC-4000Ka	20.20 to 21.20 GHz
	17.70 to 18.70 GHz (optional band)
	18.70 to 19.20 GHz (optional band)
	19.20 to 20.20 GHz (optional band)
Output Frequency Range	950 to 2000 MHz
Input/Output Impedance	50Ω
Input Return Loss	18 dB minimum
Output Return Loss	15 dB minimum
Input Connector	N, Female (C-, X-, and Ku-Band)
Output Connector	N, Female
Gain	15 dB nominal at minimum attenuation
User Attenuation Range	0 to 10 dB, in 0.25 dB steps (0.1 dB opt)
Output Power, P1dB	+ 10 dBm minimum
Third Order Intercept	+ 20 dBm minimum
Carrier Spurious	-60 dBc

## DCS-4000 Combined Transfer Characteristics

Gain	50 dB nom at minimum attenuation
Gain Adjustment	50 dB, 0.25 dB steps (0.1 dB opt)
Gain Adjustment Accuracy	1.0 dB over 30 dB range
Gain Stability	±0.25 dB/day at constant temperature ±1.0 dB over temperature
Receive Phase Noise	Exceeds requirements of MIL-STD 188-164A
Noise Figure	15 dB max, at minimum attenuation
Image Rejection	60 dB minimum
AM/PM Conversion	0.1 deg/dB, max, to -5 dBm output
Group Delay:	
Linear	±0.05 ns/MHz
Parabolic	±0.01 ns/MHz <sup>2</sup>
Ripple	1 ns p-p
Third Order Intercept	+20 dBm minimum
Amplitude Response	±0.50 dB over any 36/72 MHz ±1.1 dB over full band

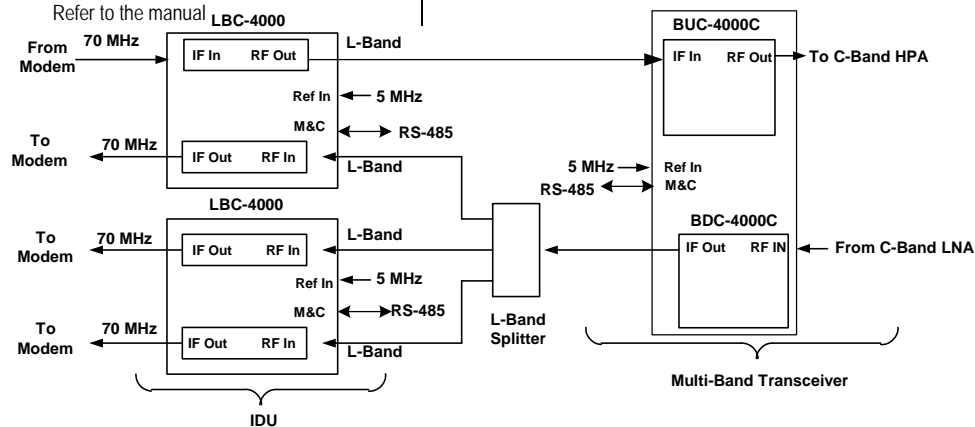

# MBT-4000B Outdoor Multi-Band RF Transceiver



## INTRODUCTION

Comtech EF Data's MBT-4000B Multi-Band RF Transceiver is designed to perform L-Band to C or Ku RF up conversion and support an LNB for C or Ku RF to L-Band down conversion. Additionally, the MBT-4000 provides the following features:

- Neither DC nor 10MHz are required from the modem, greatly simplifying multi-carrier and redundant operations
- Easy expansion for providing a redundant system or other frequency bands
- Rugged construction for mobile and transportable applications
- Automatic band identification for the BUC, LNB, and antenna feed (if the feeds provide an identifying connector)
- Easy system status verification via LEDs located behind a removable cover

## SYSTEM OVERVIEW

The transceiver is constructed in a modular configuration. Common to the configuration for any frequency band of operation is a base module, which provides the M&C, Power Supply, and Reference function along with a tri-plexer for providing DC and 10 MHz to an LNB. Band-specific BUC modules can be quickly mounted to the base module with clip type fasteners. BUC and LNB modules for other bands and spares for all modules can be stored in a transit case until needed.

## INSTALLATION AND OPERATION

The Common Module may be near or on the antenna. The band specific BUC is latched into place on top of the Common Module, while the LNB is mounted to the antenna's OMT. The cables to the antenna and the IDU complete the installation.

## LNB SUPPORT

The OMT mounted LNB amplifies and translates a band specific input frequency block (C band or one of three Ku band s) down to L-Band in the 950 to 2000 MHz range. Because of the design of the MBT 4000B base unit, neither DC nor 10MHz are required from the modem.

## BLOCK UP CONVERTER (BUC-4000)

The BUC-4000 translates the modems L-Band output carrier to the desired output frequency(C or Ku) with an output level capable of driving an HPA. Like the Rx side, no DC or 10 MHz reference is required from the modem.

## BUC-4000C, Ku

C-Band: 5850 to 6650 MHz

Ku-Band: 13.75 to 14.50 GHz

- No spectral inversion
- 10 dB gain adjustment

## Multi-Carrier/Redundant operation

Multi-carrier and redundant operation is greatly simplified by eliminating the requirement for DC and 10 MHz from the L band interface.

The MBT 4000B monitors the bias current of the LNBs and can control a Rx WG switch. Similarly, it monitors the BUC and the external amplifier status for Tx WG switch control.

# MBT-4000B Outdoor Multi-Band RF Transceiver

## BUC-4000 Block Up Converter ODU

Input Frequency Range	950 to 2000 MHz
Output Frequency By Model:	
BUC-4000C	5860 – 6650 MHz
BUC-4000Ku	13.75 – 14.50 GHz

Input/Output Impedance	50Ω
Input Return Loss	15 dB minimum
Output Return Loss	18 dB minimum
Input Connector	Type – N, female
Output Connector	N, Female (C- and Ku-Band)
Gain	15 dB nominal at minimum attenuation (18 dB for Ku-Band BUC)
User Attenuation Range	0 to 10 dB
Output Power, P1dB	+10 dBm minimum
Third Order Intercept	+20 dBm minimum
Carrier Spurious	-60 dBc
Non-Carrier Spurious	-60 dBm
External Reference	Input, either 5 or 10 MHz ±5 dBm optional

## Environmental and Physical

Operating Temperature:	
ODU: BUC-4000	-40° to +50°C (-40° to 122°F)

Operating Humidity	5 to 95 non-condensing
Operating Altitude	10,000 ft above sea level
Non-Operating Temperature:	
ODU: MBT-4000	-50° to +71°C (58° to 160°F)
Prime Power	90 to 260 VAC, 47 to 63 Hz
Size	Refer to the manual

## Typical LNB Characteristics

LNB Input Frequency By Model:

C Band Input Frequency	3.625 to 4.200 GHz
Noise Figure	≤ 35°K.
Ku Band Input Frequency Options	10.95 to 11.70 GHz 11.70 to 12.20 GHz 12.25 to 12.75 GHz
Noise Figure	1.0 dB max
Output Frequency Range	950 to 2000 MHz(depends on RF band)

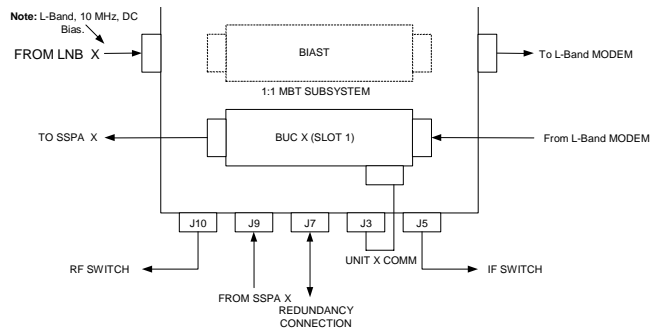

**MBT-4000B**

Typical Tx/Rx Redundant System  
(1:2 splitters/combiners may be substituted for the L-Band Input/Output switches)

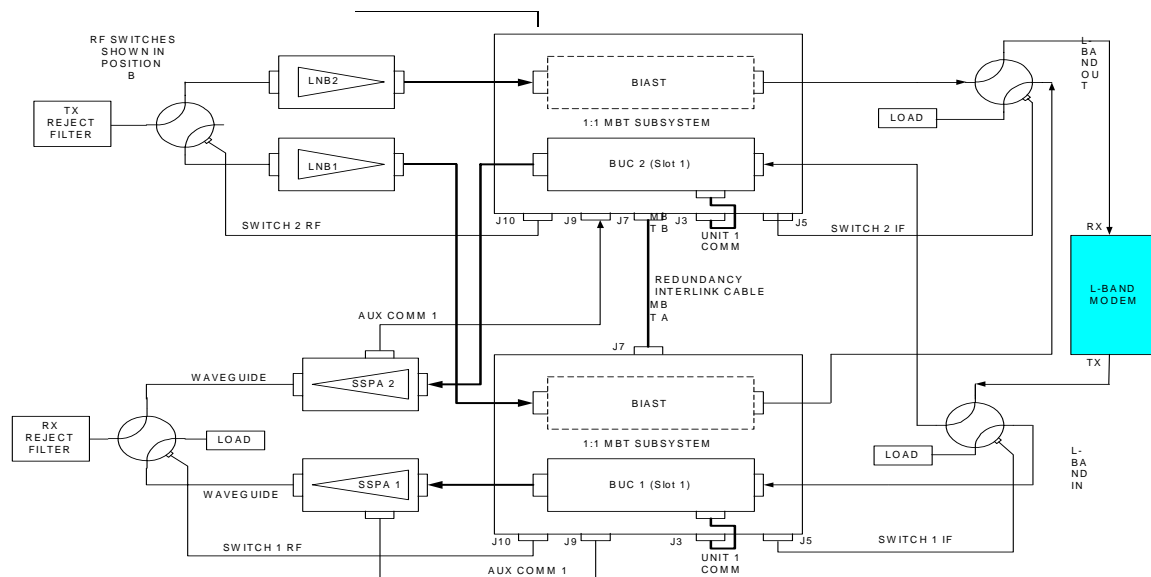

COMTECHEFDATA

DUAL MBT-4000 REDUNDANT SWITCH



Optimizing Satellite Communications



www.comtechefdata.com